



**Tech Craft**  
Advertising & Signs LLC

**2022**

[www.techcraftdubai.com](http://www.techcraftdubai.com)



**PRE-QUALIFICATION PROFILE**  
**SIGNAGE & ADVERTISING SERVICES**

# TABLE OF CONTENTS

REPLY TO COMMENTES	4
ISO CERTIFICATES	6
TOTAL SOLUTIONS	10
PROJECT CONSULTANTY/MANAGEMENT	11
COMPLETED PROJECTS	12
RECENTLY COMPLETED PROJECTS	41
ONGOING PROJECTS	48
RESIDENTIAL BUILDING PROJECTS	60
OUR CLIENTS	64
ORGANIZATIONAL CHART & CV'S	66
LIST OF MACHINES	81
COMMERCIAL LICENSE	84
PREVIOUS APPROVALS	87
LIST OF PROJECTS	118
RECOMMENDATION LETTERS	123
COMPANY CONTACT DETAILS	126



<b>REPLY TO COMMENTS</b>		
<b>S/N</b>	<b>Comments</b>	<b>Remarks</b>
1	Valid ISO certifications and local authority approval shall be included	ISO 14001; ISO 45001 & ISO 9001 Certificates Enclosed
2	Historical contract agreements shall be included	Please refer to pages 117 - 121
3	The general construction experience history is within 2 years. Demonstrate by providing previous approvals on specific constructions experience in key activity related to similar project.	Please refer to pages 86 - 116
4	Provide list of completed projects showing the sub-contractor experience in similar scale projects and high rise, list of projects should include but not limited to project description, year of completion, signage package cost, Client, Consultant and main Contractor.	Please refer to pages - 5
5	Provide list of ongoing projects with similar scale.	Please refer to pages - 5
6	Provide CVs for the technical team, safety and QC/QA and include them in the organization Chart for the project.	Please refer to pages 66 - 79
7	Provide recommendation letters from previous clients and projects.	Please refer to pages 86 - 116
8	Turnover to be provided and submitted separately to T & T	Noted & shall comply

## REPLY TO COMMENTS

List of Completed Projects	Description	Area (sq.m)	Cost of Signage Package	Contractor	Consultant	Owner
<b>COMPLETED ROJECTS</b>						
1. Canada Pavillion	Free Standing, Internal & External Signage	11,264 sq.m.	350,000.00	Amana	Ellisdon	Canada
2. Bloom Heights	Signage/Wayfinding/Parking Signs	407,105 sq.m	280,000.00	Al Arooba	Al Khawajah Engineering Consultancy	Bloom Holdings
3. Schlumberger	Internal, External Signage & Parking Signs	822,830 sq.m.	600,000.00	Amana	Arkiplan Consulting Architects & Engineers	Schlumberger Emirates
4. Saadiyat (AUH Beach)	Internal & Wayfinding Signages	291,750 sq.m.	475,000.00	Nael Bin Harmal	Target Engineering	Nael Bin Harmal Real Estate
<b>ON-GOING PROJECTS</b>						
1. AZIZI Projects	Azizi Building / 17 Buildings - Internal & Parking Signages	38,520 sq.m.	500,000.00	Azizi Progress / Azizi Al Shamandi	360 ·Degrees Contracting Company	Azizi
2. AL ZAHIIYA	Internal/Parking & Wayfinding Signages	90,709.80 sq. m.	1,100,000.00	UNEC (United Engineering Construction Company)	Engineering Consultant Group	Majid al Futtaim
3. OMNIYAT	Internal/External/Parking Signages	258,225 sq.m.	1,700,000.00	Shapoorji	Arkiplan Consulting Architects & Engineers	Omnayat
4. JOTUN PROJECT	Internal Signage – Façade Sign Signage Tower	13,699 sq.m.	1,900,000.00	Amana	Arcadis	Jotun

International Organization for Standardization

# ISO

## **ISO CERTIFICATE**

CERTIFICATION





# CERTIFICATE

This is to certify that the  
Environmental Management System of

**TECH CRAFT ADVERTISING & SIGNS L.L.C**

**P.O.Box 487131, Dubai Investment Park 2, Dubai - UAE.**

has been found to comply with

**ISO 14001:2015**

This certificate is applicable to the following scope:

**Manufacture, Supply, Installation and Service of Signage and Advertisement Products.**

**Certificate No :: BESC202207030**

Date of Initial Registration	30 July 2022
Surveillance Audit on/before	30 June 2023
Certificate Expiry	30 July 2023
Recertification due	29 July 2025

MANAGEMENT SYSTEM CERTIFICATE



*Handwritten signature*

Authorized Signatory  
**BQC ASSESSMENT PRIVATE LIMITED**

Website: [www.bqccert.com](http://www.bqccert.com), E-mail: [info@bqccert.com](mailto:info@bqccert.com),

BQC Assessment Pvt. Ltd. is accredited by International Accreditation Services (IAS), United States of America vide MSCB Number 124. Accreditation details are available with IAS, (International Accreditation Service) Inc. USA, at [www.iasonline.org](http://www.iasonline.org). The validity of this certificate can be verified at [www.bqccert.com](http://www.bqccert.com) or through [info@bqccert.com](mailto:info@bqccert.com). Address: 202, DLF Galleria, Mayur Vihar, Delhi -110091. This certificate is the property of BQC Assessment Pvt. Ltd. and must be returned on request.



# CERTIFICATE

This is to certify that the  
Occupational Health & Safety Management System of

**TECH CRAFT ADVERTISING & SIGNS L.L.C**

**P.O.Box 487131, Dubai Investment Park 2, Dubai - UAE.**

has been found to comply with

**ISO 45001:2018**

This certificate is applicable to the following scope:

**Manufacture, Supply, Installation and Service of Signage and Advertisement Products.**

**Certificate No :: BOSC202207033**

Date of Initial Registration	30 July 2022
Surveillance Audit on/before	30 June 2023
Certificate Expiry	30 July 2023
Recertification due	29 July 2025

MANAGEMENT SYSTEM CERTIFICATE



*Handwritten signature*

Authorized Signatory  
**BQC ASSESSMENT PRIVATE LIMITED**

Website: [www.bqccert.com](http://www.bqccert.com), E-mail: [info@bqccert.com](mailto:info@bqccert.com),



# CERTIFICATE

This is to certify that the  
Quality Management System of

**TECH CRAFT ADVERTISING & SIGNS L.L.C**

**P.O.Box 487131, Dubai Investment Park 2, Dubai - UAE.**

has been found to comply with

**ISO 9001:2015**

This certificate is applicable to the following scope:

**Manufacture, Supply, Installation and Service of Signage and Advertisement Products.**

**Certificate No :: BQSC202207044**

Date of Initial Registration	30 July 2022
Surveillance Audit on/before	30 June 2023
Certificate Expiry	30 July 2023
Recertification due	29 July 2025

MANAGEMENT SYSTEM CERTIFICATE



*Handwritten signature*

Authorized Signatory  
**BQC ASSESSMENT PRIVATE LIMITED**

Website: [www.bqccert.com](http://www.bqccert.com), E-mail: [info@bqccert.com](mailto:info@bqccert.com),



## TOTAL SOLUTIONS

Tech Craft Advertising & Signs LLC is a total Advertising and Signage Solution Company, with a fully-equipped, industry-leading facility located in Dubai Investment Park 2, Dubai. Every day, a team of dedicated, passionate and creative professionals strive hard to deliver unmatched quality and a variety of contemporary signs; catering to prestigious projects, including but not limited to: Shopping Malls, Corporate Offices, Banks and Financial Institutions, Hospitals, Retail Chains, Restaurants, and Universities.

With significant technical and logistic support from Tech Craft Advertising & Signs LLC, time bound projects and convention signage, visual exhibitions, events and heavy engineering assignments like traffic sign gantries, unipoles, and tri-vision signs may be executed at any volume.

From conceptual designing to installation all kinds of internal and external signs made to order, as per the clients' requirements, at our ultra-modern factory premises aided by the most modern CNC Router, Laser Machine, Digital Printers etc.

In addition, Tech Craft Advertising & Signs LLC is proud to be recognized as market leaders in frosted film works. This sand-blasted effect – on glass – provides ambient light and enhances the privacy of executive corporate office spaces.

## PROJECT CONSULTANCY/MANAGEMENT

Proposing suitable designs and material in consideration of the building architecture, geographical, and statutory requirements. This also includes the preparation of bill of quantity, schematic, final designs and shop drawings according to the layout plan of the building.

Floating tenders, selection of potential suppliers, short-listing suppliers, scrutinizing and finalization of samples and materials and value engineering.

Quality survey at suppliers' factories, during the execution and final quality and quantity verification process.

Verification of as-built drawings, operation and maintenance manuals, taking over certificate, warranty certificate, product data sheets, and re-order formats.





**COMPLETED PROJECTS**  
**EXPO 2020**

# EXPO 2020 PROJECTS



# CANADA PAVILION-EXPO 2020

COMPLETED PROJECTS  
EXTERNAL SIGNAGE



# CANADA PAVILION-EXPO 2020

## COMPLETED PROJECTS

### EXTERNAL & WAY FINDING

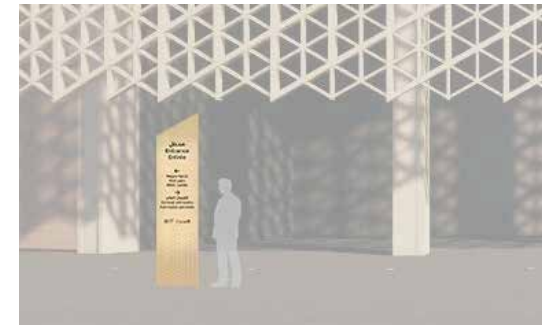
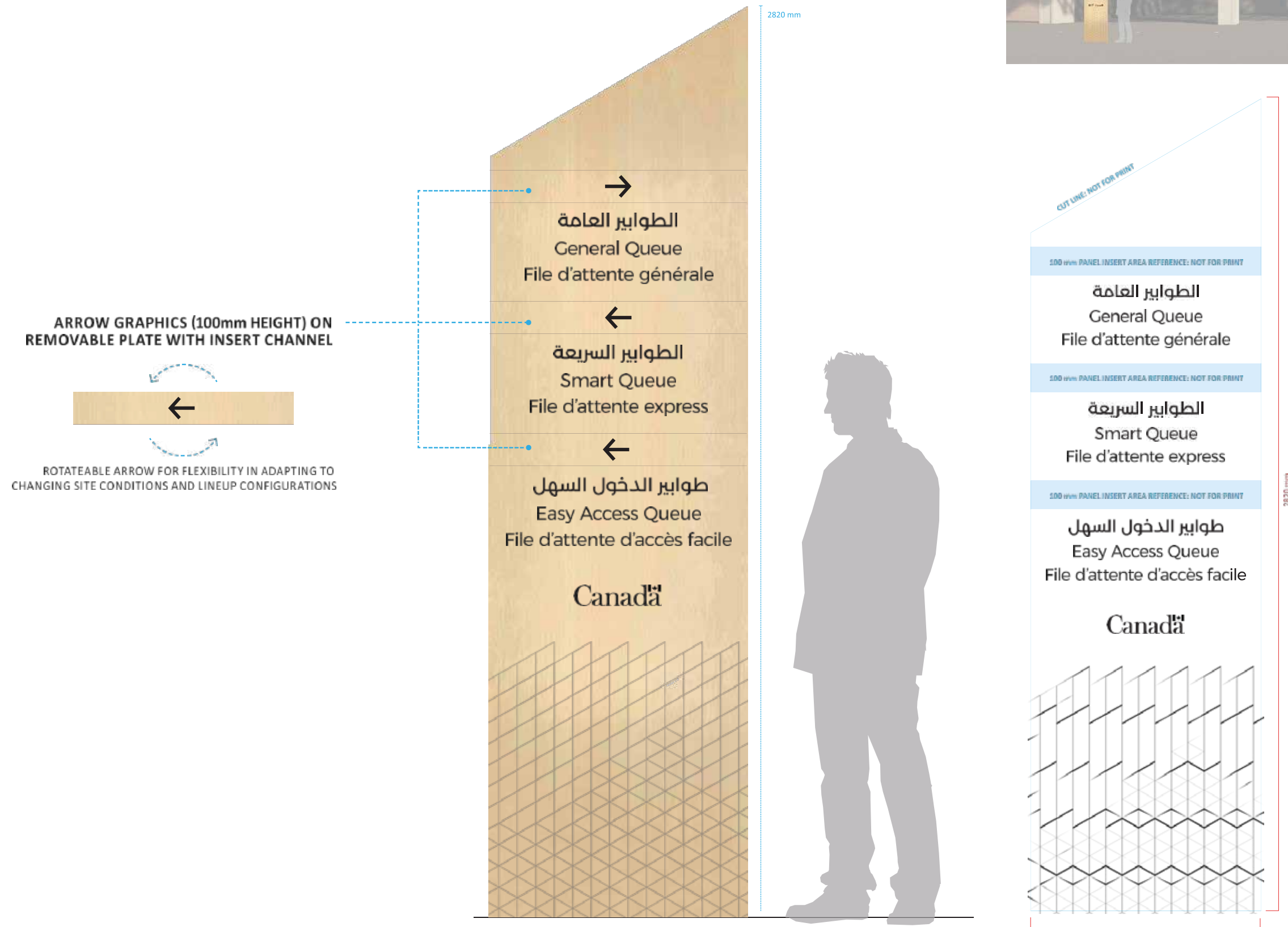

# EXPO LIVE PAVILION-EXPO 2020

COMPLETED PROJECTS

EXTERNAL SIGNAGE



# EXPO LIVE PAVILION-EXPO 2020

COMPLETED PROJECTS

INTERNAL SIGNAGE



غرفة التخزين  
Storage Room

غرفة الكهرباء  
Electrical Room

غرفة أمن  
Security Room

## SECTION

INTERNAL DOOR SIGNAGE



HIGH QUALITY UV PRINT  
COLOR (RAL9003)

2mm thick aluminum

2mm thick aluminum

HIGH QUALITY UV PRINT



# EXPO LIVE PAVILION-EXPO 2020

COMPLETED PROJECTS

INTERNAL SIGNAGE



# ARGENTINA PAVILION-EXPO 2020

COMPLETED PROJECTS

EXTERNAL SIGNAGE

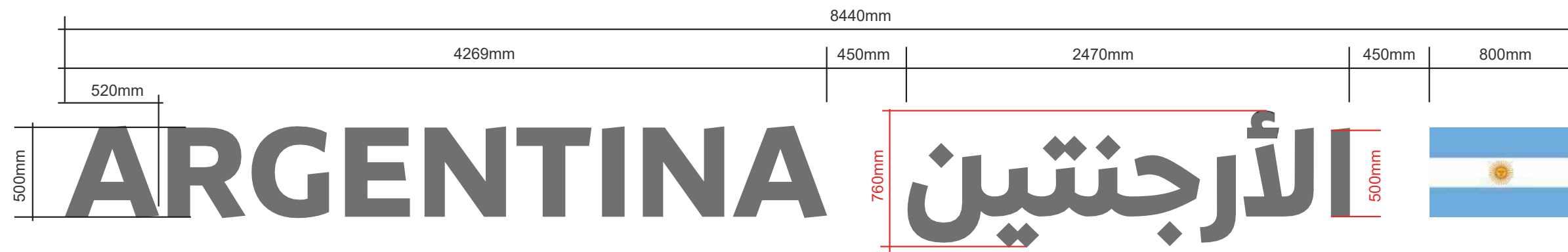

# ARGENTINA PAVILION-EXPO 2020

COMPLETED PROJECTS

EXTERNAL SIGNAGE

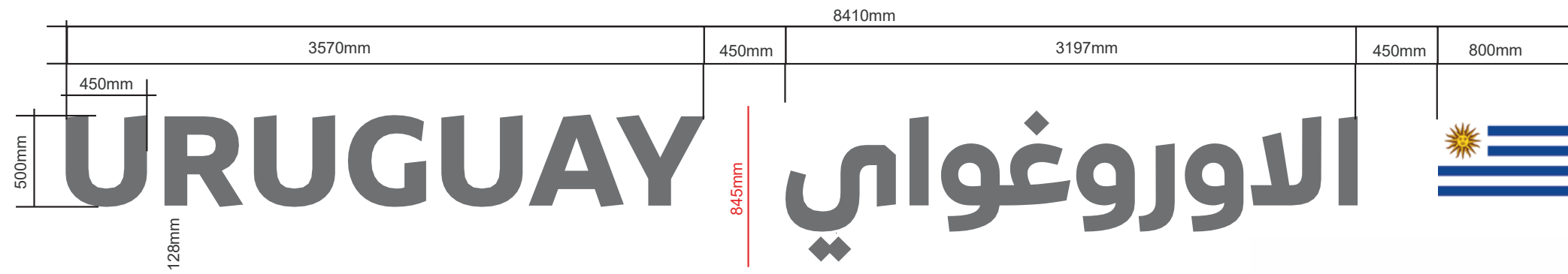

# ARGENTINA PAVILION-EXPO 2020

COMPLETED PROJECTS

EXTERNAL SIGNAGE

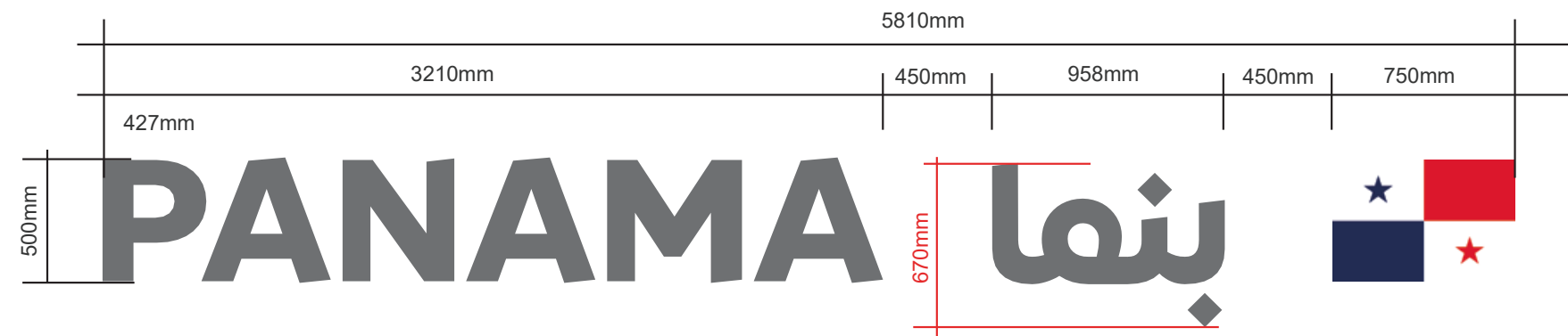

# AL REEF LABANESE BAKERY-EXPO 2020

COMPLETED PROJECTS

EXTERNAL SIGNAGE



# AL FARWANIA -EXPO 2020

COMPLETED PROJECTS

EXTERNAL SIGNAGE



### INTERNAL SIGNAGE

YOU'RE A CUTEA

Air line Joint Signage

3000mm

260mm

154mm

260mm



# TROPICCOOL -EXPO 2020

COMPLETED PROJECTS





# IRAQ PAVILION-EXPO 2020

COMPLETED PROJECTS

INTERNAL PROJECTS



300mm

صالة كبار الشخصيات  
VIP Lounge

Message will be High Quality UV print  
with Varnish effect (Pantone 677C)

2mm Thick Aluminum with High Quality Grey (RAL 9016) UV Print

صالة الطعام العراقية  
Iraqi Dining Table

المنطقة المظلة  
Shaded Area

حمام الرجال  
Male Toilet

غرفة تبديل ملابس السيدات  
Female Changing Room

المطبخ  
Pantry

مدخل كبار الشخصيات  
VIP Entrance

حمام السيدات  
Female Toilet

غرفة المؤتمرات  
Conference Room



**COMPLETED PROJECTS**

# EMIRATES FLIGHT CATERING

COMPLETED PROJECTS

EXTERNAL SIGNAGE



# PARK VIEW TOWER

COMPLETED PROJECTS

EXTERNAL & INTERNAL  
SIGNAGE



# Bloom Heights / Towers Project

COMPLETED PROJECTS

INTERNAL, EXTERNAL & CAR PARKING SIGNAGE

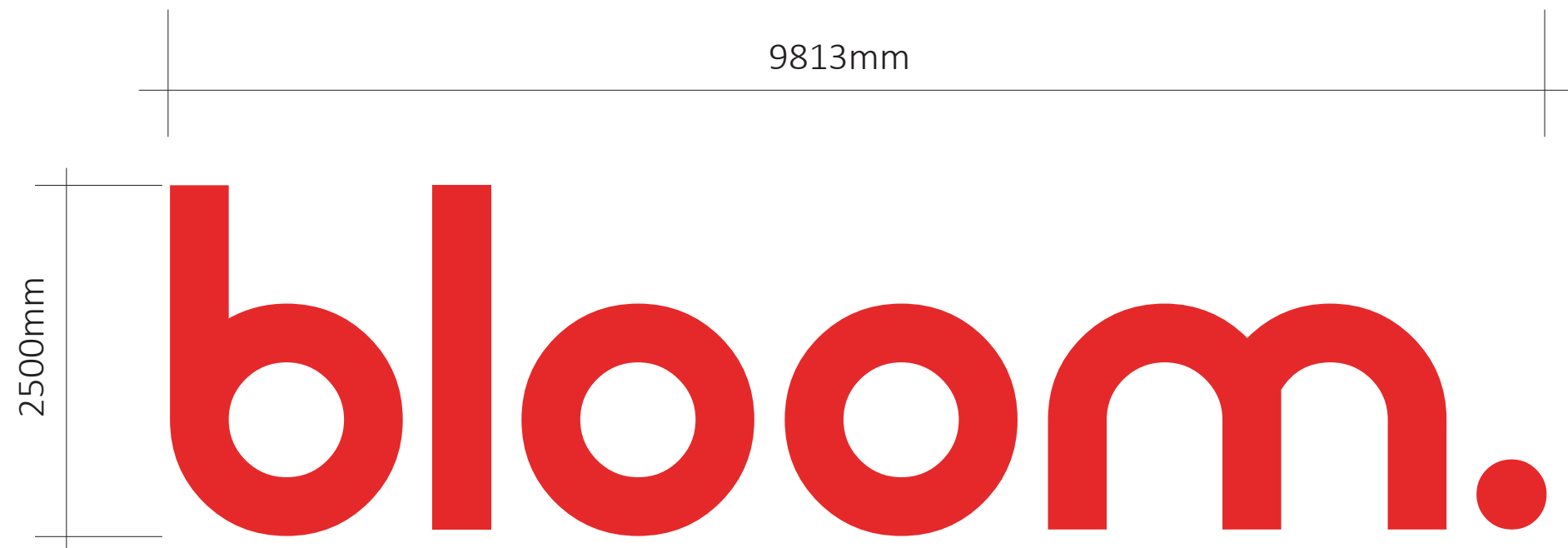

# AVENUE MALL

## COMPLETED PROJECTS EXTERNAL, INTERNAL & WAY FINDING

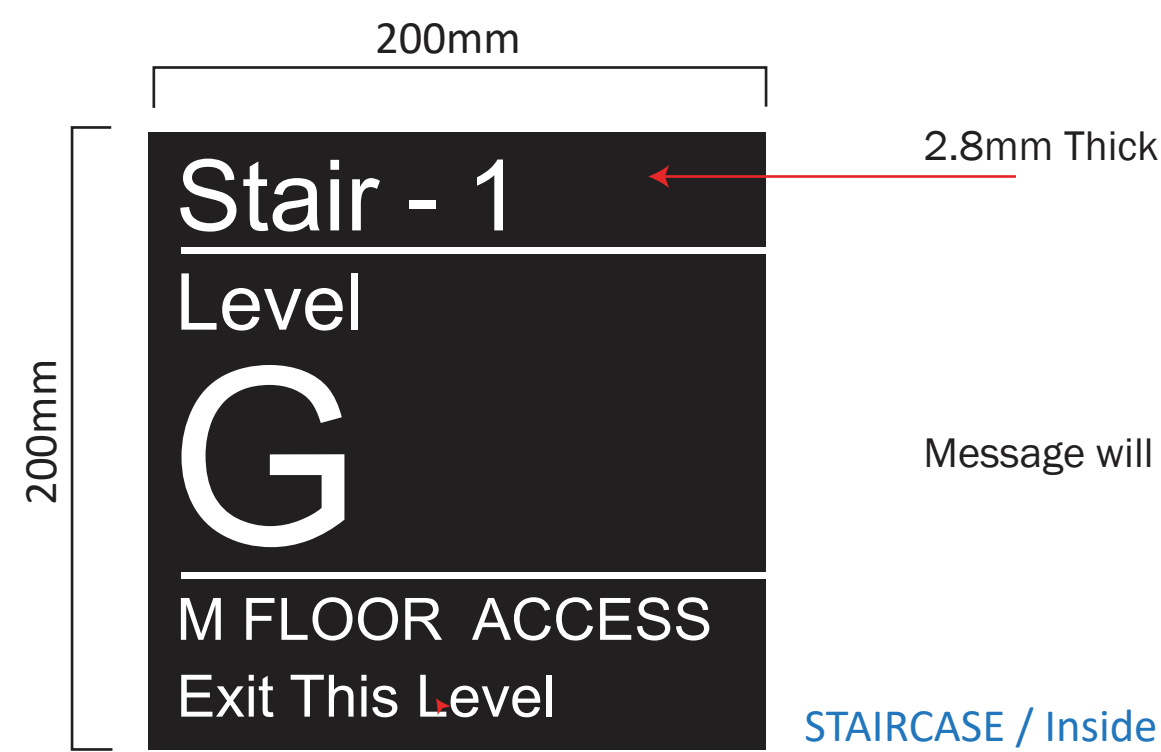
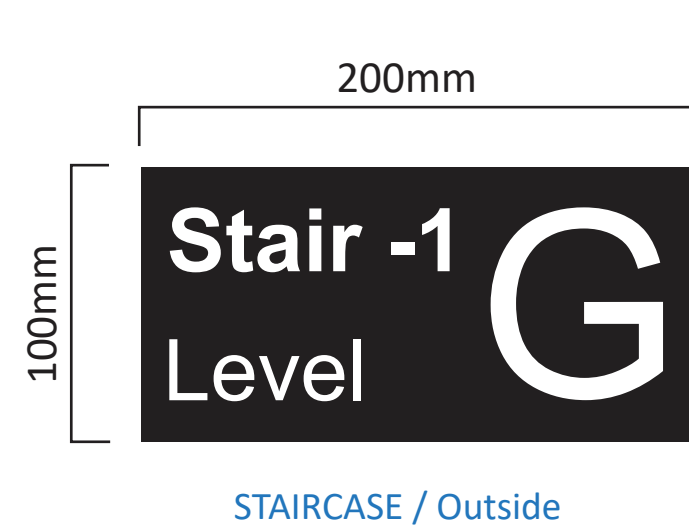
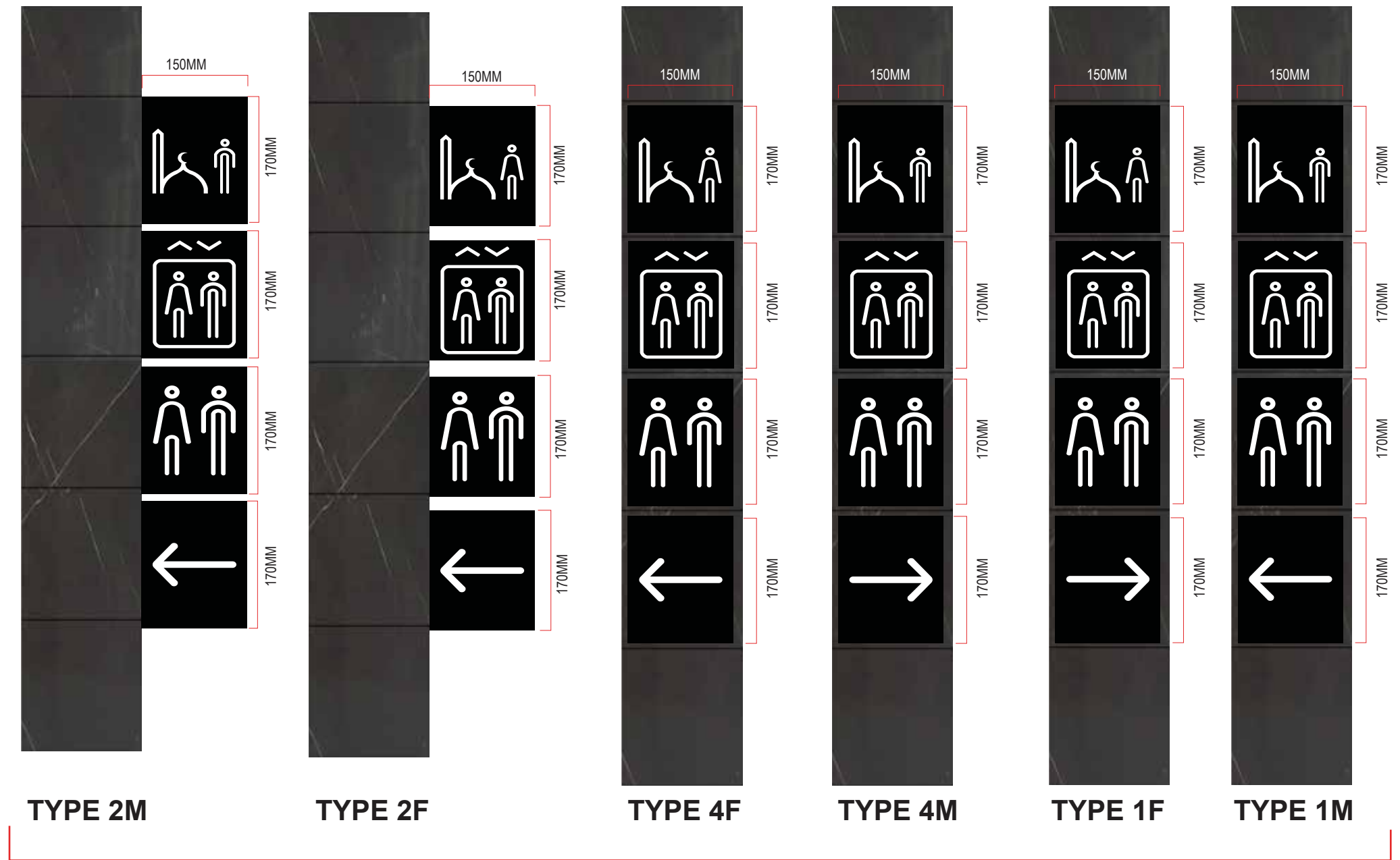

2.8mm Thick Black Mat Finish Acrylic

Message will white UV Print

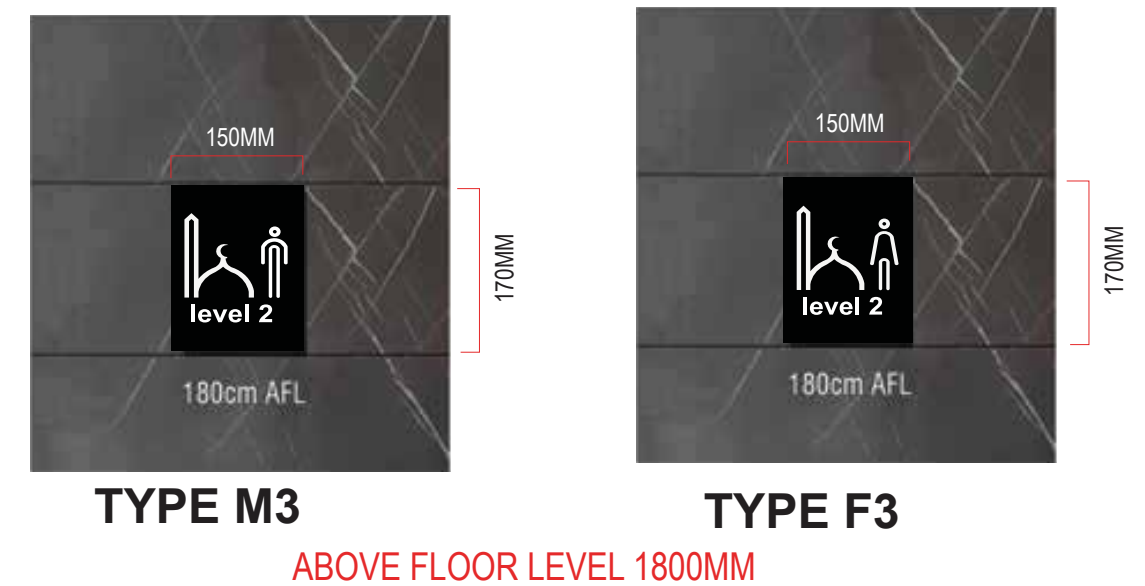

# AVENUE MALL

COMPLETED PROJECTS

EXTERNAL & INTERNAL WAY FINDING

46.58 ft

11.75ft

# AVENUE MALL



### EXTERNAL & INTERNAL SIGNAGE

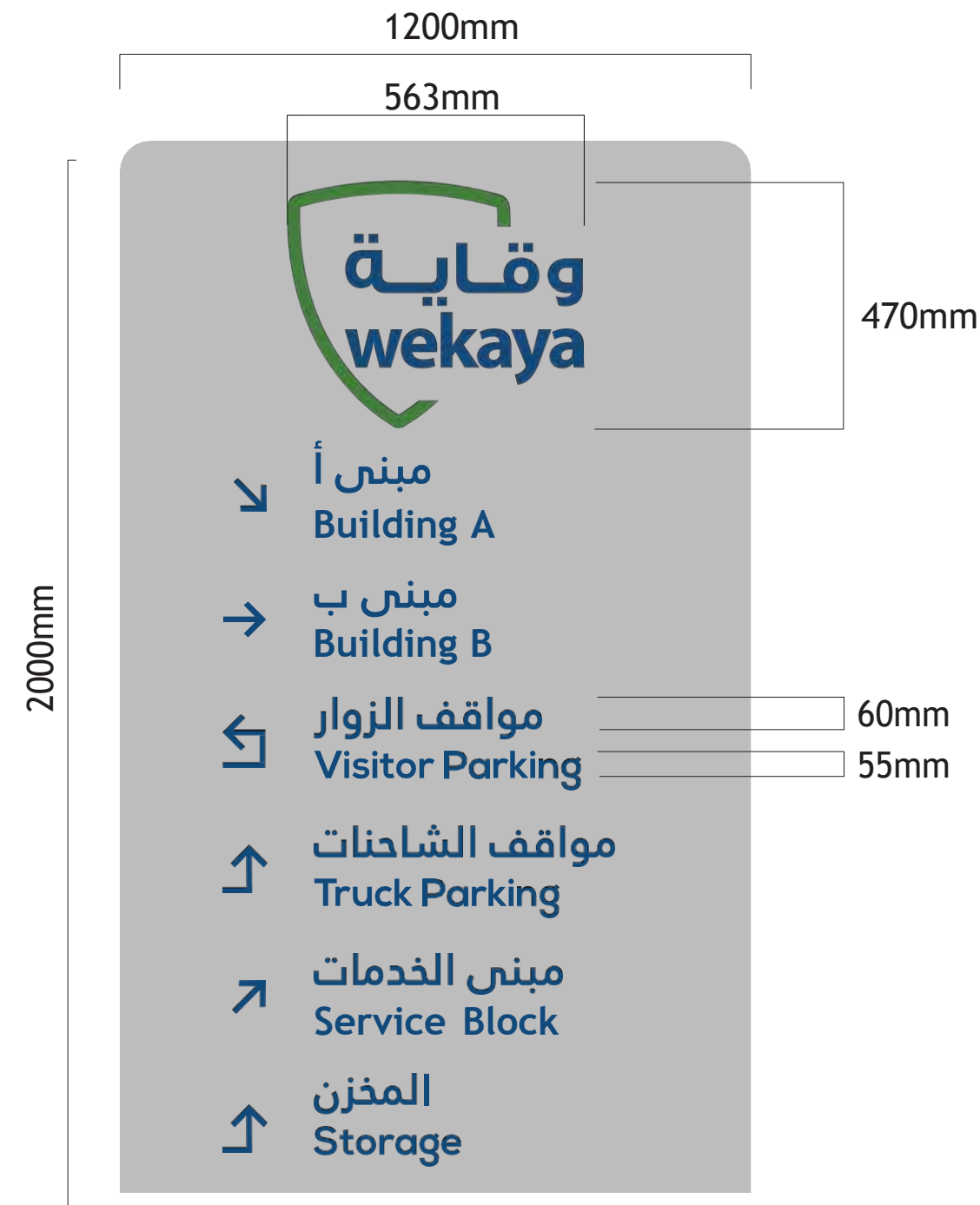



# DUBAI INSURANCE BUILDING

## COMPLETED PROJECTS EXTERNAL & INTERNAL SIGNAGE

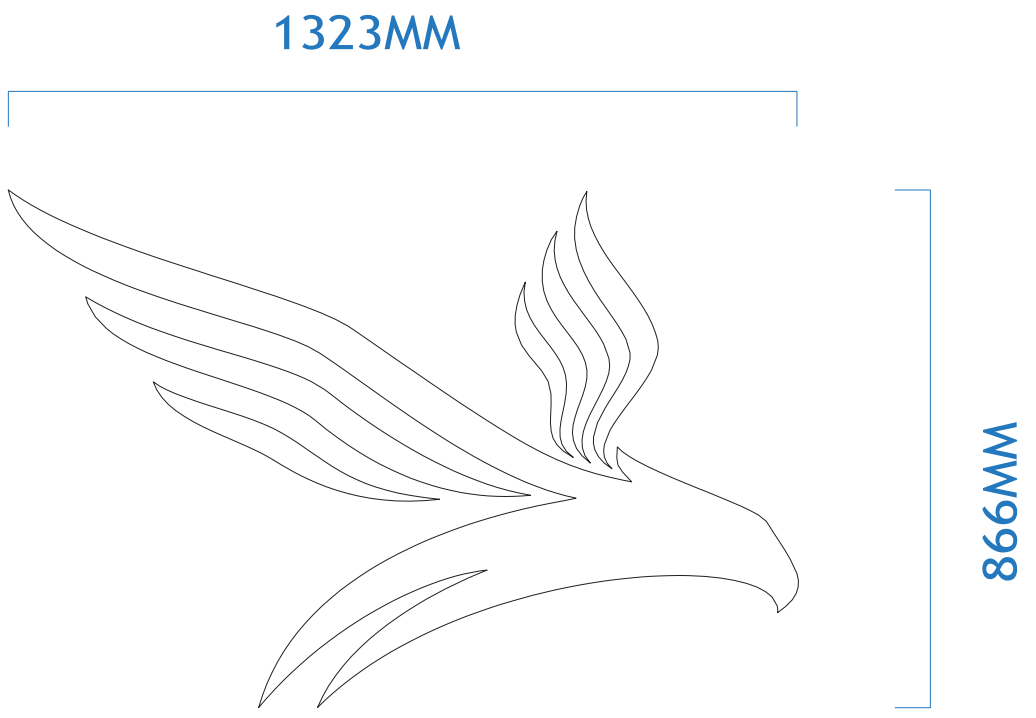
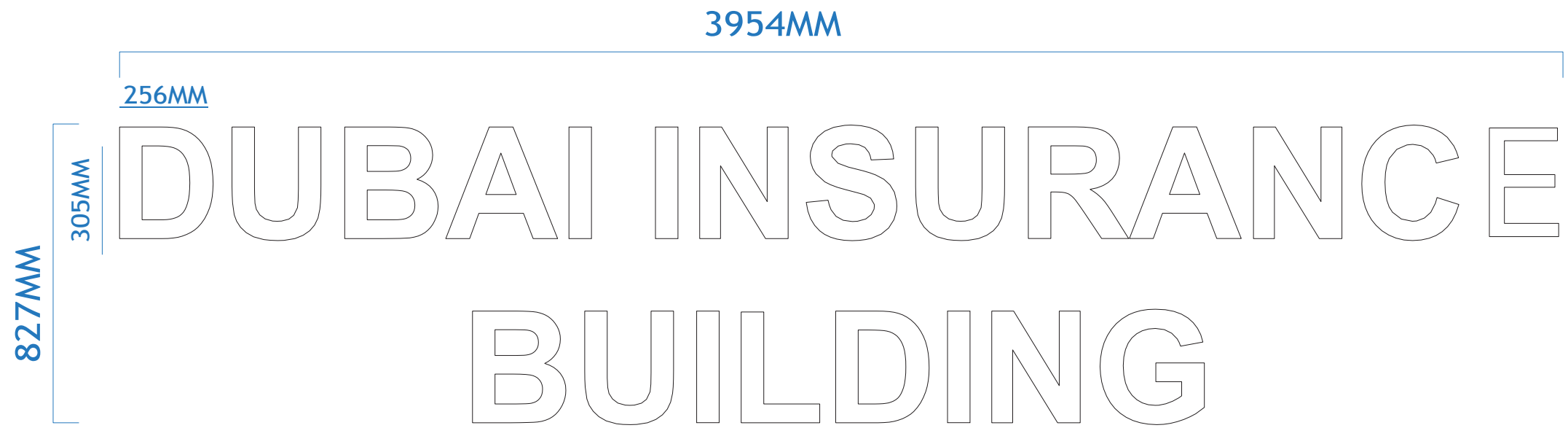

# MURAQQABAT POLICE STATION

COMPLETED PROJECTS

EXTERNAL SIGNAGE

DUBAI POLICE



# MAF/AZUT CLUB HOUSE & KIOSK

COMPLETED PROJECTS

INTERNAL SIGNAGE

445mm  
45mm  
17mm  
45mm  
غرفة الشبكات  
Server Room

206 mm  
45mm  
17mm  
45mm  
مكاتب  
Offices  
170mm



# THE PEARL RESIDENCES ( AT SAADIYAT)

## COMPLETED PROJECTS

### INTERNAL, EXTERNAL & CAR PARKING SIGNAGE

- 1:Aluminum 3mm with paint finishing
  - 2:Aluminum 2mm with paint finishing
  - 3:White acrylic 4mm lasser cutting w/ Paint Finish
- Size 1900mmX 800mm H



# THE PEARL RESIDENCES ( AT SAADIYAT)

COMPLETED PROJECTS

## EXTERNAL & INTERNAL WAY FINDING



# DU DATA CENTER (DUBAI-ABU DAHBI)

## COMPLETED PROJECTS

### EXTERNAL & INTERNAL SIGNAGE

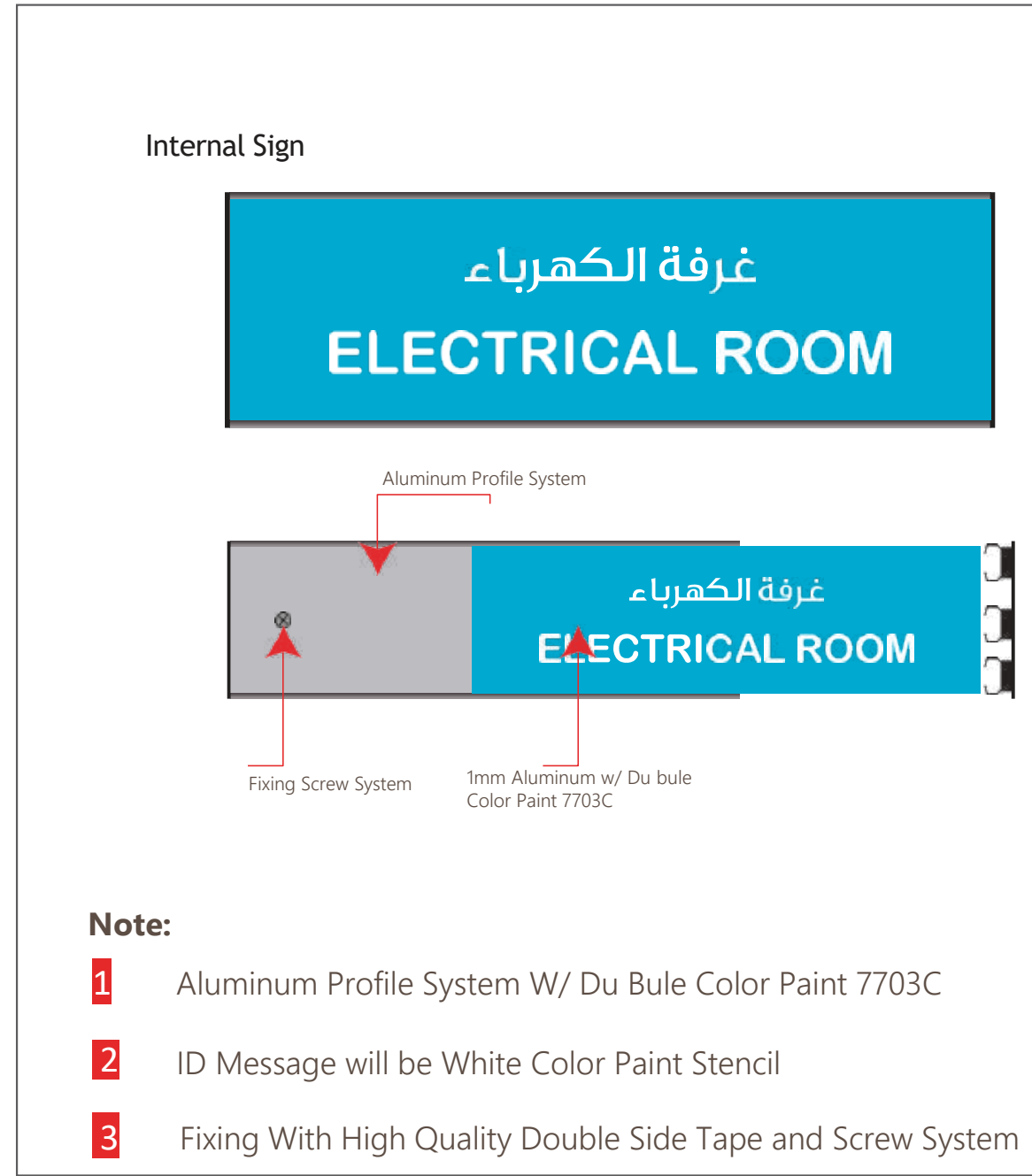
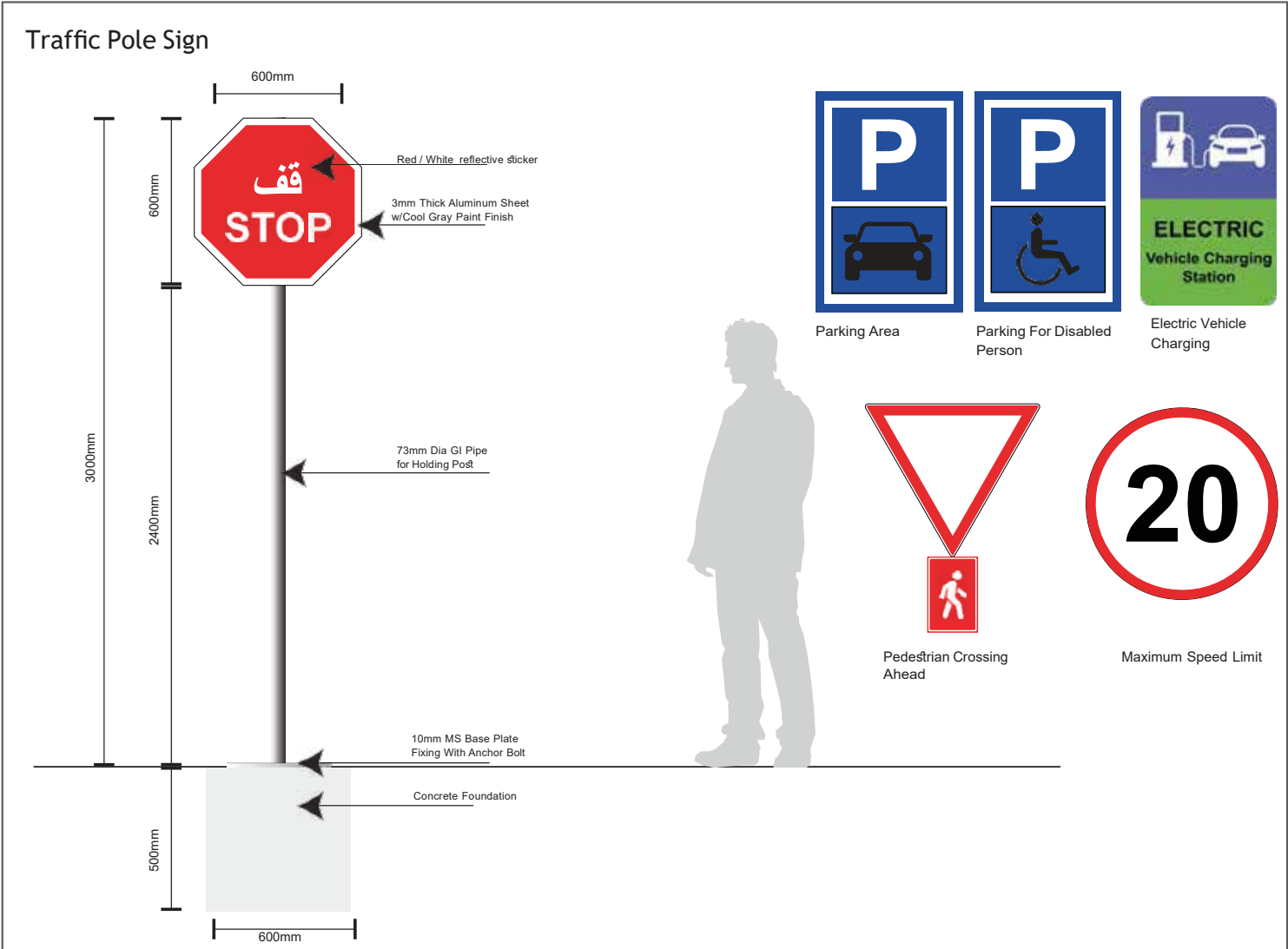



A modern shopping mall interior with digital displays and people. The scene is brightly lit with a clean, contemporary aesthetic. In the foreground, a man in a dark jacket and light-colored pants is interacting with a digital queue number display showing '09'. To his right, a man in a blue shirt and tan pants is walking away. Further right, a woman in a blue dress is looking at her smartphone. In the background, there are various digital displays, including one for 'LG gram' laptops and another for 'COVID-19 NEW'. A sign above a glass entrance reads 'Season off'. The overall atmosphere is one of a busy, high-tech retail environment.

# RECENTLY COMPLETED PROJECTS



# AEROFARM

## RECENTLY COMPLETED PROJECT

### INTERNAL & WAY FINDING

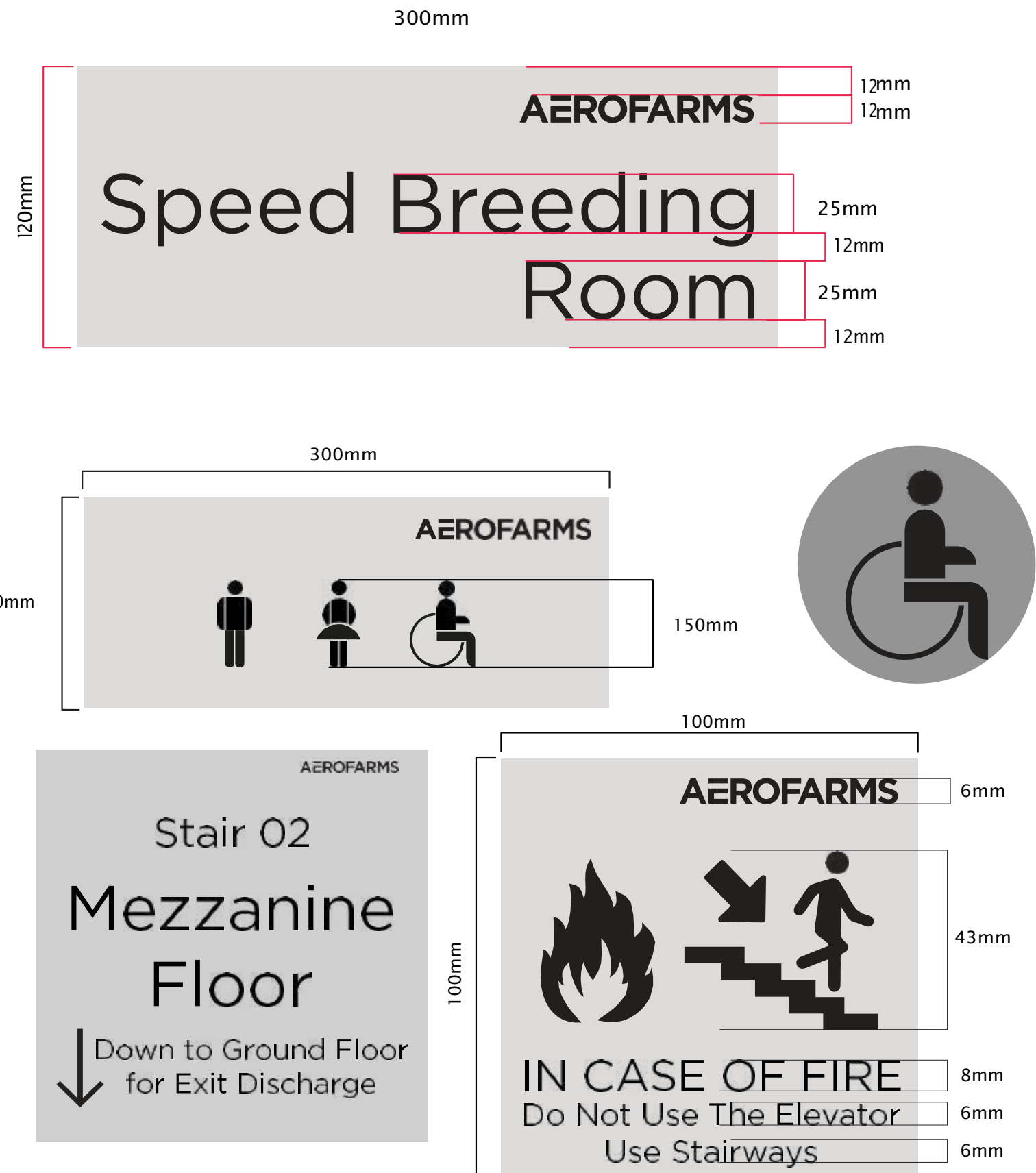

# SCHLUMBERGER

RECENTLY COMPLETED PROJECT  
EXTERNAL SIGNAGE



# SCHLUMBERGER

## RECENTLY COMPLETED PROJECT INTERNAL SIGNAGE

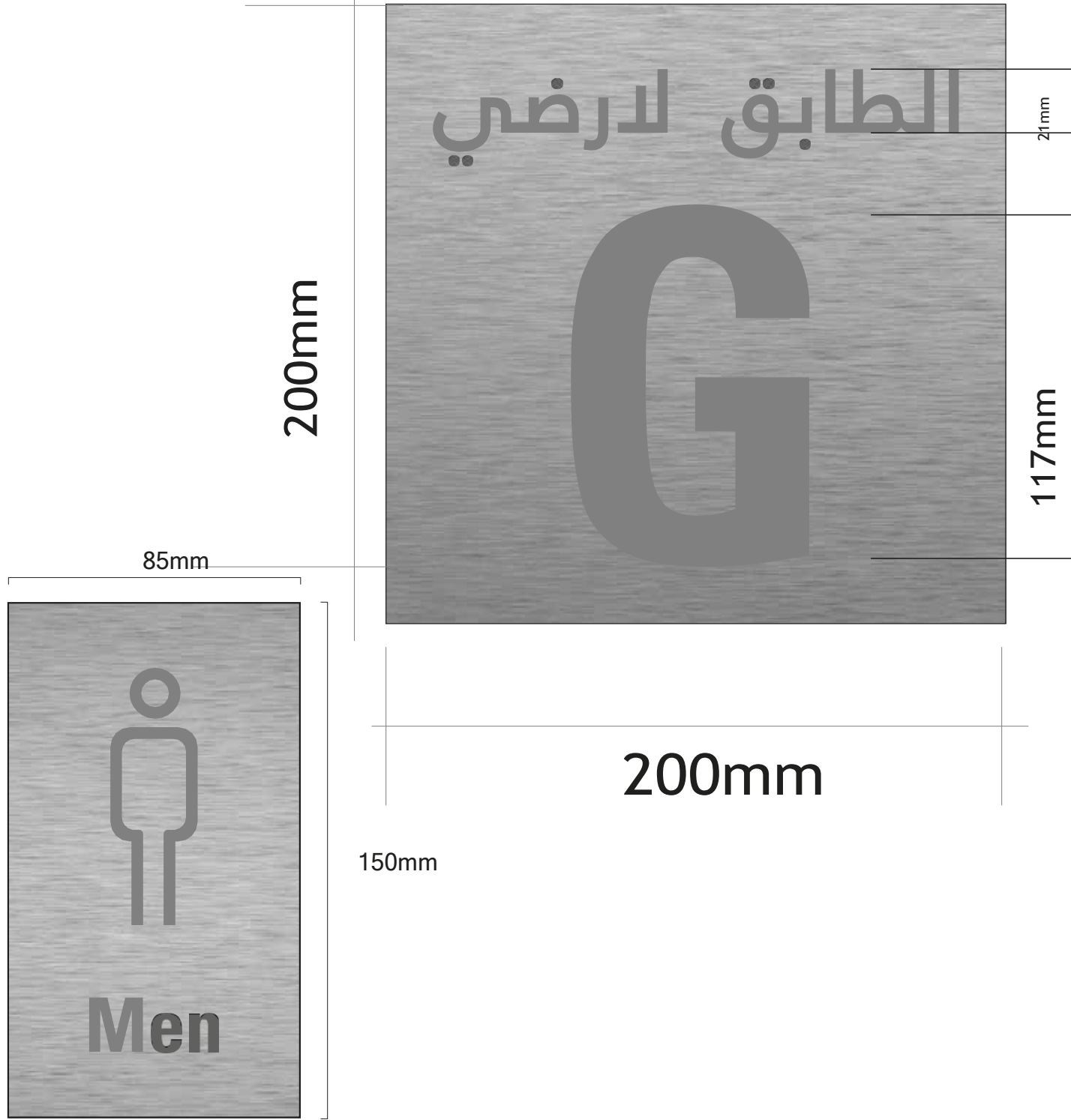
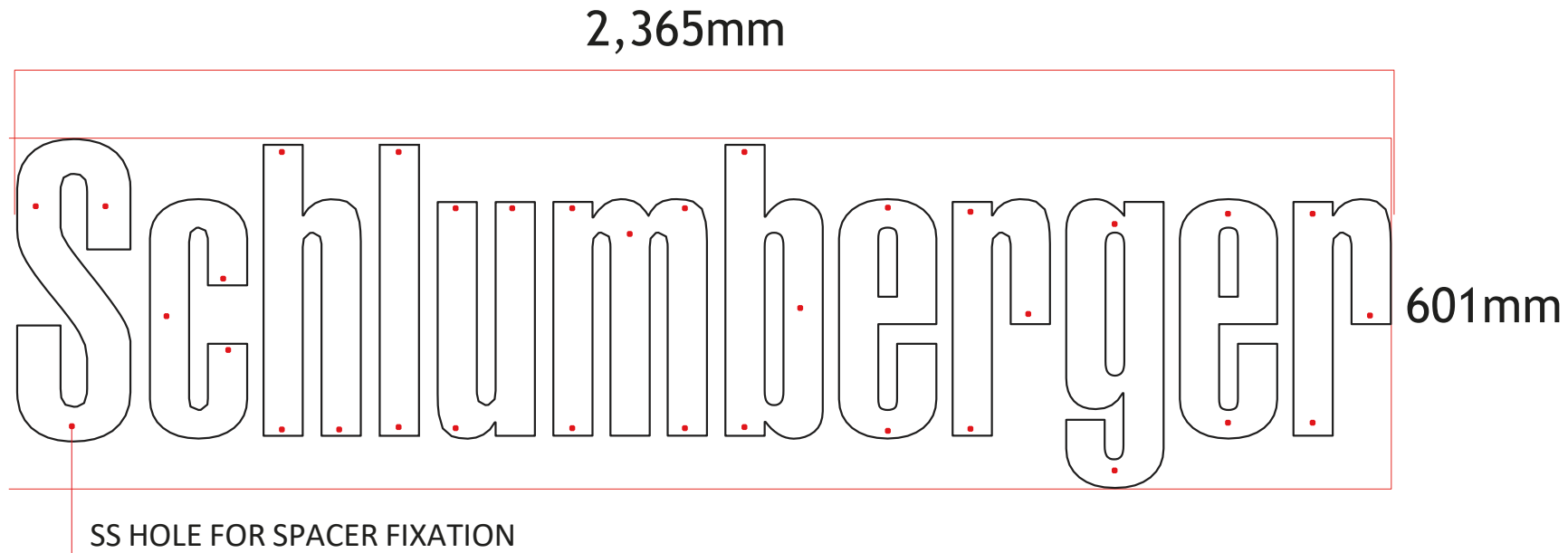

# VERTICAL FARM/MIDDLE EAST

RECENTLY COMPLETED PROJECT

EXTERNAL SIGNAGE



# VERTICAL FARM/MIDDLE EAST

RECENTLY COMPLETED PROJECT

INTERNAL SIGNAGE



# CARPET FACTORY

RECENTLY COMPLETED PROJECT

INTERNAL / TRAFFIC SIGNAGE

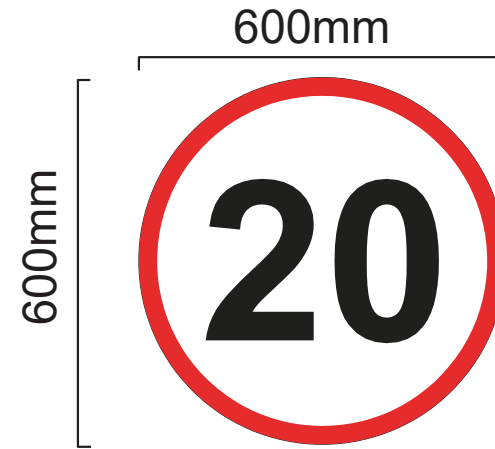

MAX SPEED QTY:9

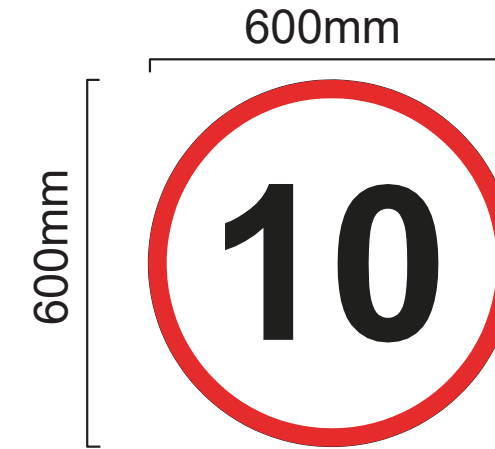

MAX SPEED QTY:4

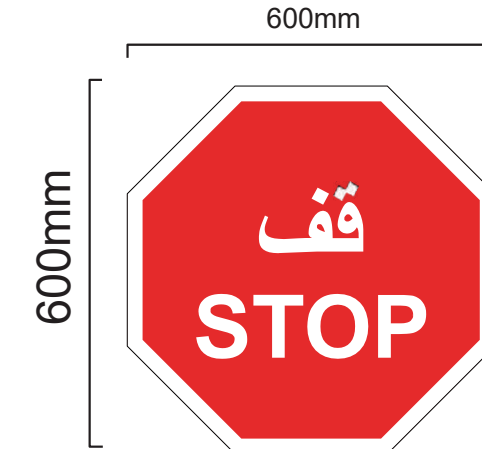

Sign STOP QTY:3

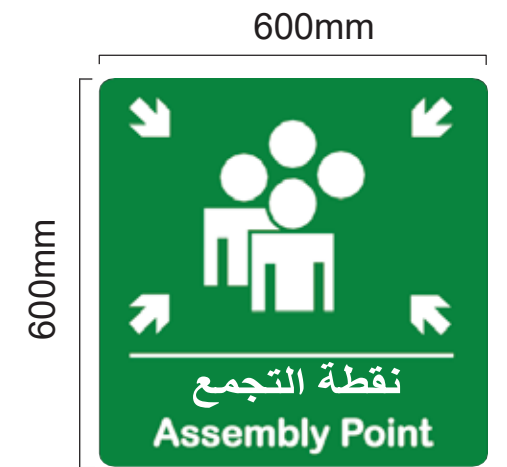

Assembly Point QTY:2

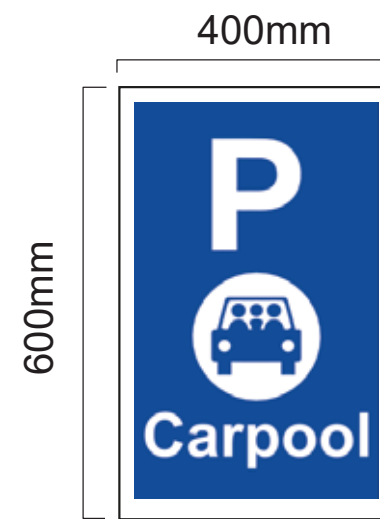

Car Pool QTY:2



Throw Rubbish Sign QTY:2

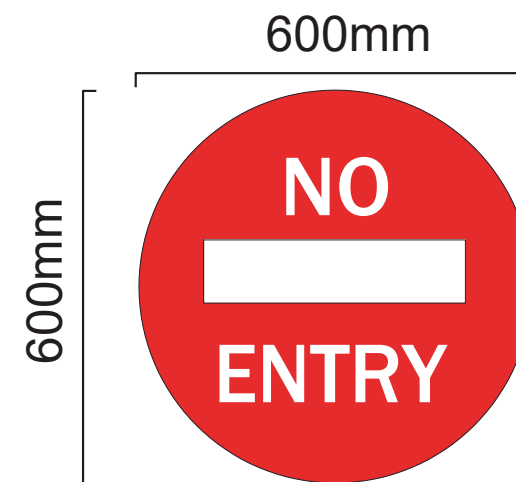

QTY:2

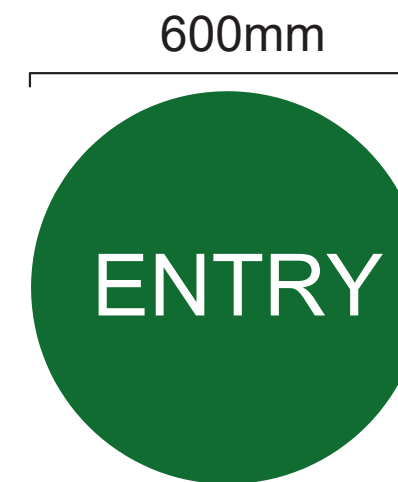

QTY:2

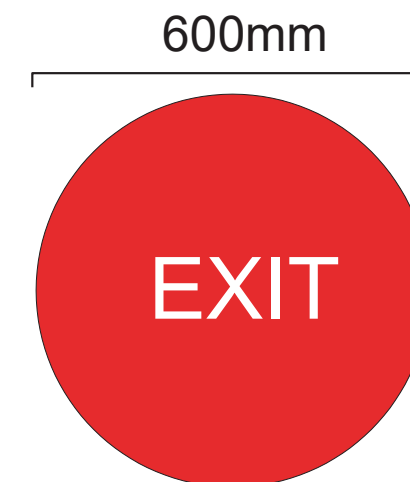

QTY:2

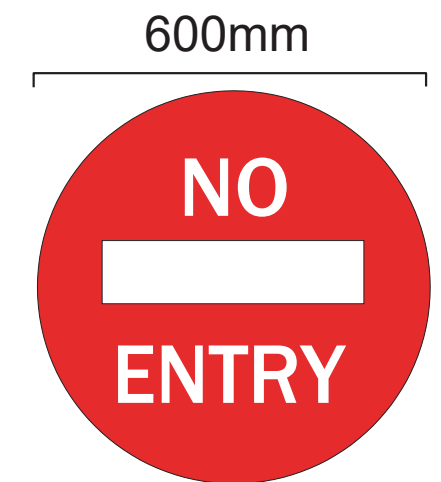

QTY:2



# ONGOING PROJECTS

# JOTUN MIDDLE EAST HQ

ON-GOING PROJECT

LOGO TOWER

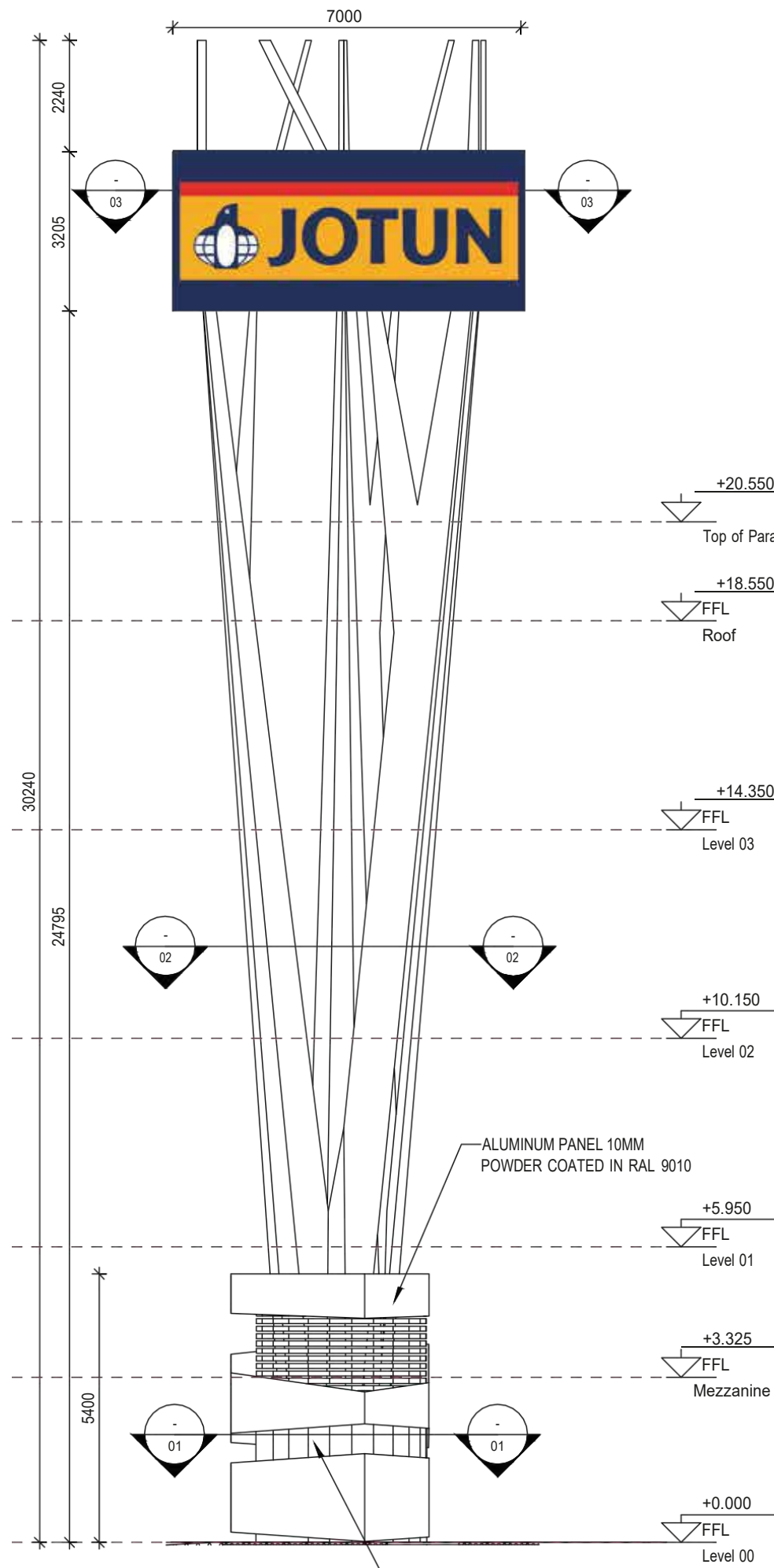

# MERAAS / LA MER



# JOTUN MIDDLE EAST HQ

ON-GOING PROJECT

FACADE SIGNAGE



ON-GOING PROJECT

FACADE SIGNAGE

# MAF/AL ZAHIA UPTOWN

ON-GOING PROJECT

INTERNAL SIGANGE

# 207



# الطابق الأرضي Ground Floor

1.2 SS brush Finish cut out letters  
(satin copper coating)

WALL SURFACE

SECTION

سلم  
Stair 1

لا منفذ للسطح  
No roof access

مستوي  
Level

# G

الخروج في  
الطابق الأرضي  
Exit at  
Ground level

# MAF/AL ZAHIA UPTOWN

ON-GOING PROJECT

EXTERNAL, EXTERNAL & WAY FINDING

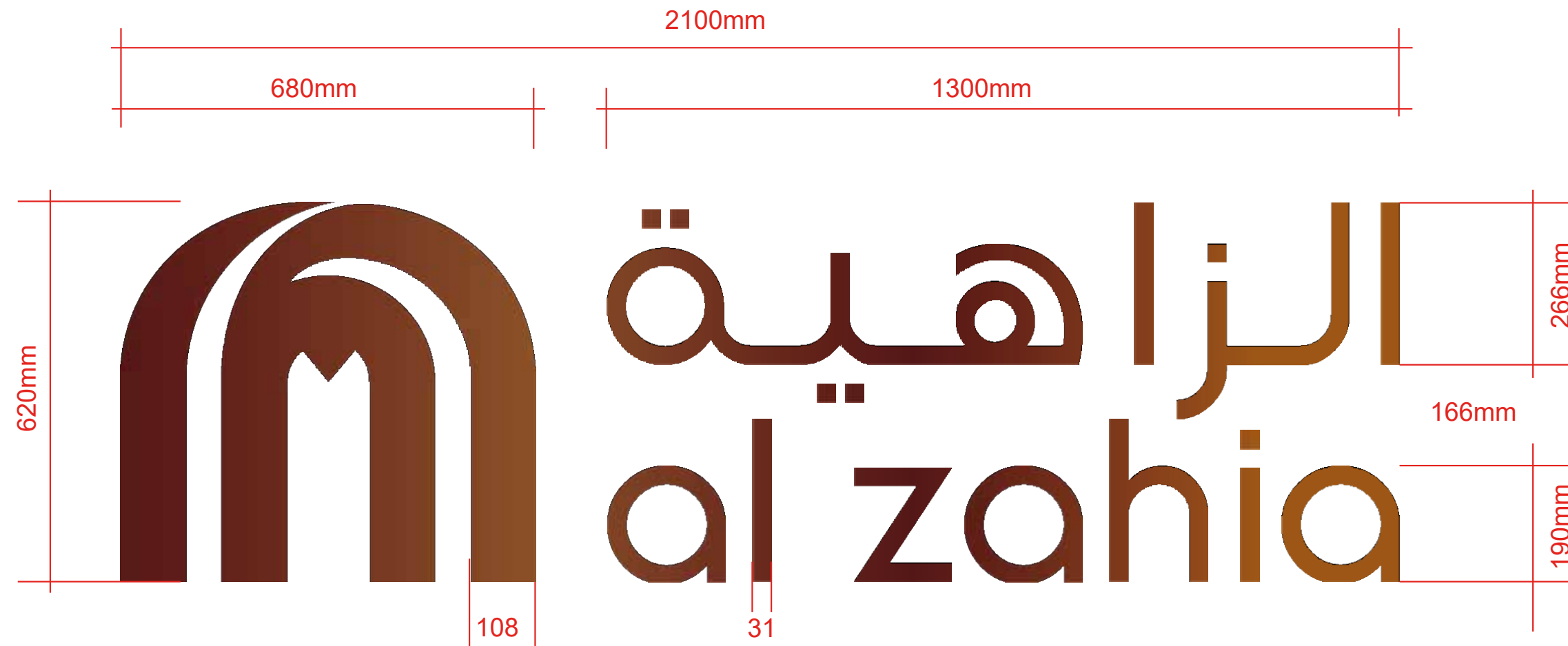

# MAF/AL ZAHIA UPTOWN

ON-GOING PROJECT

CARPARKING SIGNAGE



CP.U.01.AI



CP.U.02.AI



CP.U.03.AI



CP.U.04.AI

# DHAFRA AIR CRAFT BASE

ONGOING PROJECT

INTERNAL SIGNAGE

102  
Electrical Room

B23154-LAMH  
Large Aircraft  
Maintenance  
Hangar

EXIT

128  
Men's Locker  
Room (Dirty)

123  
Men's Toilet  
(Clean)

116  
Break Room

104  
Test Cell

# ATANA HOTEL

ON-GOING PROJECT

EXTERNAL SIGANGE

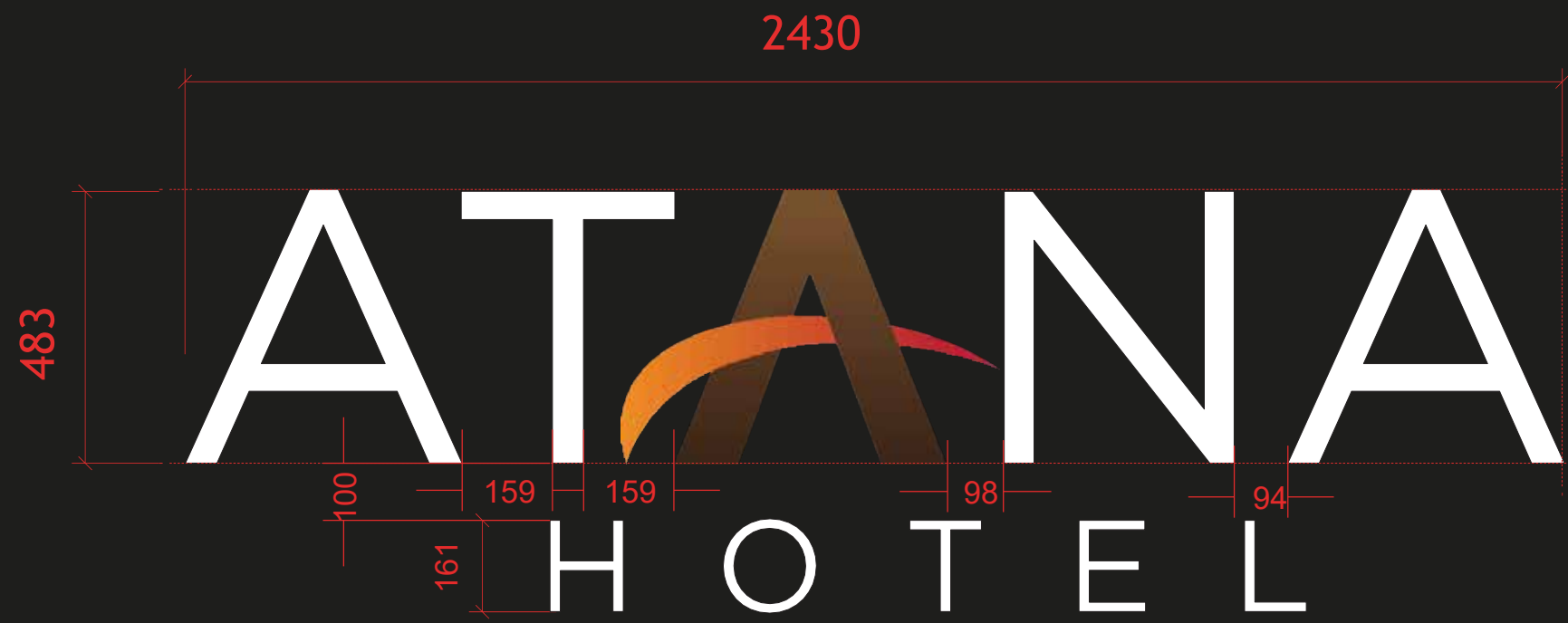

# GRAND HYATT HOTEL

ON-GOING PROJECT

INTERNAL SIGANCE



FRONT VIEW \_ SCALE 1:2

5MM THK. LASERCUT ALUMINUM LETTERS IN POLISHED GOLD FINISH - FIXED WITH WELDED PINS INTO PRE-DRILLED HOLES IN THE WALL

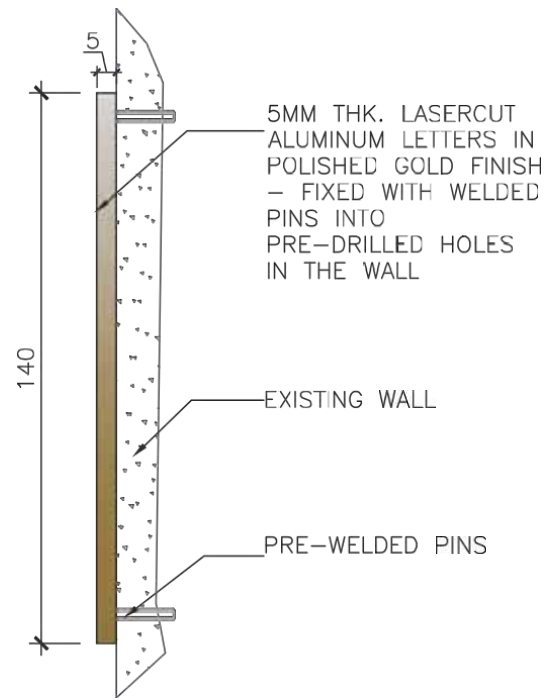

SIDE VIEW \_ SCALE 1:2

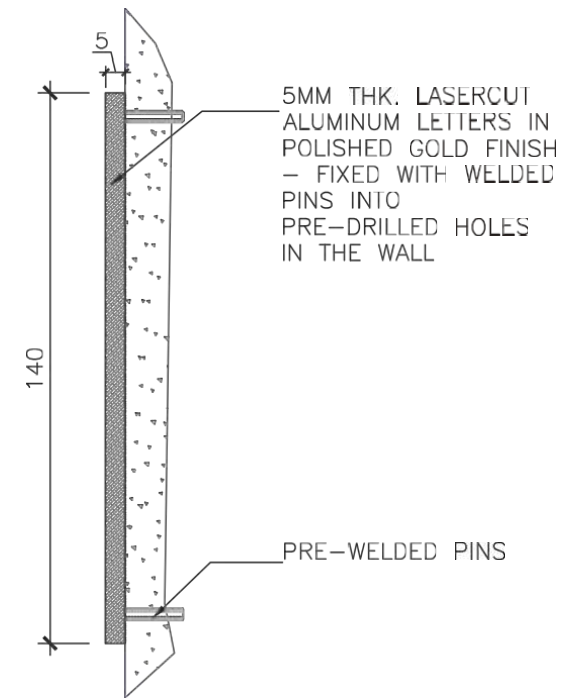

SECTION-A\_ SCALE 1:2

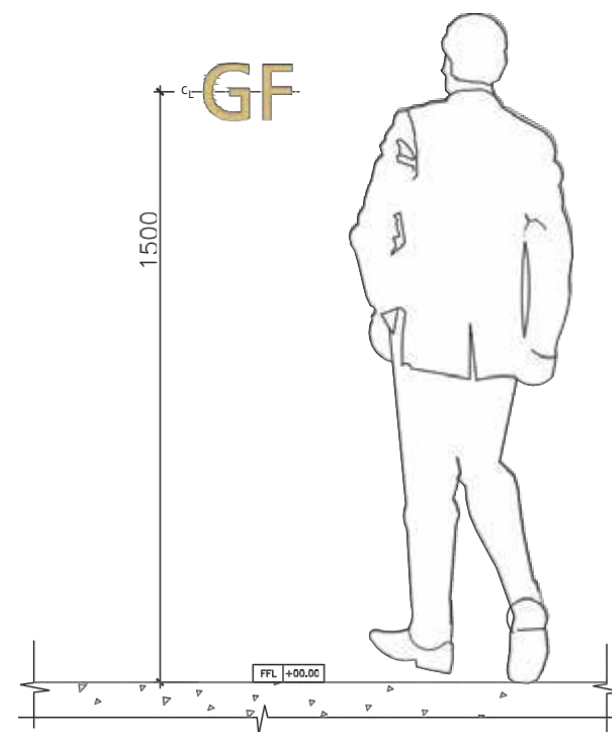

ELEVATION \_ SCALE 1:20

NOTE:  
THIS SIGN IS PLACED ONTO THE WALL HENCE THE SUPPLIER TO CONSIDER THE PIN / GLUE FIXATION

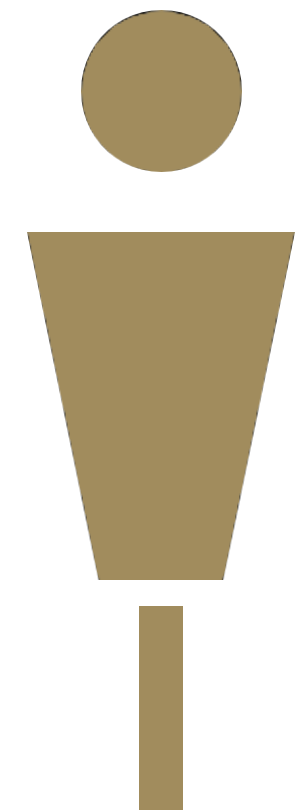

# AL SAFA SCHOOL

ON-GOING PROJECT  
INTERNAL SIGNAGE



REF IMAGE

Include changeable slot aluminum signs



REF IMAGE





# DUBAI HOLDING

ON-GOING PROJECT  
EXTERNAL SIGNAGE



# MERAAS / LA MER

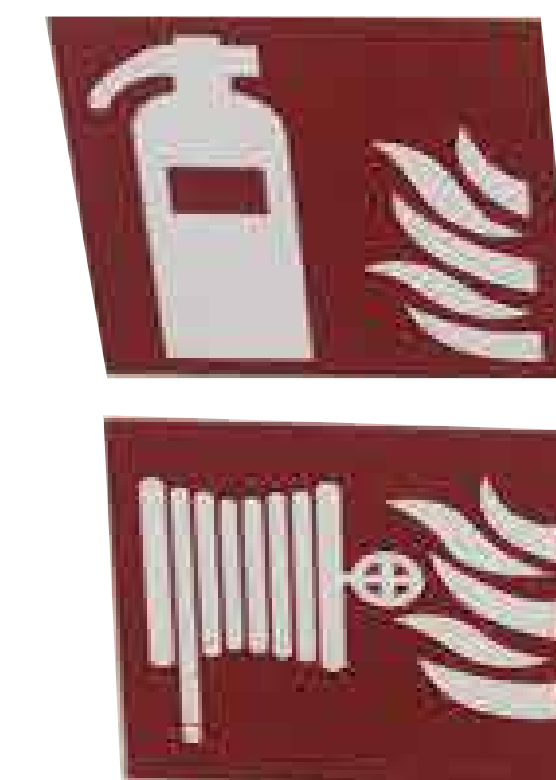
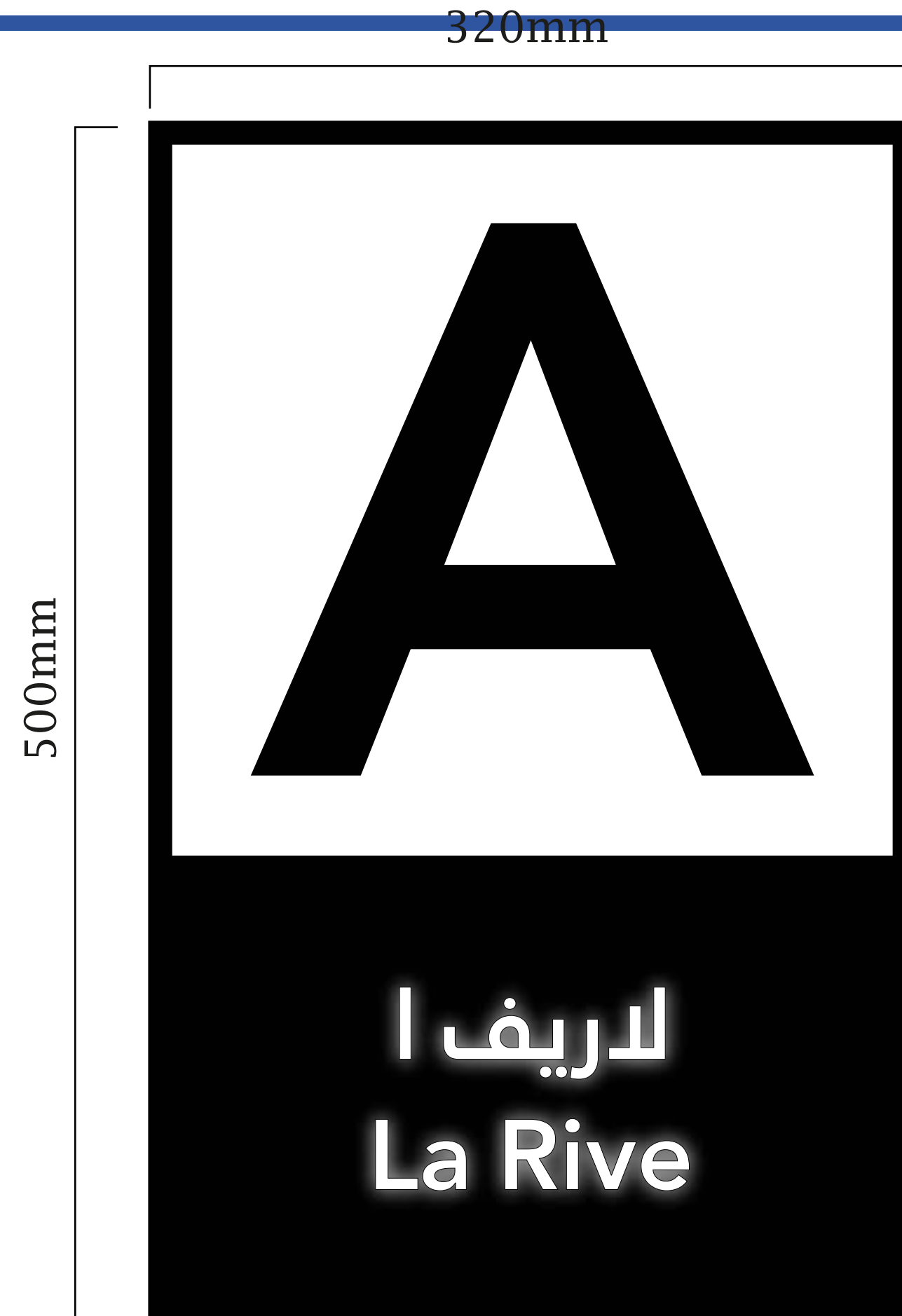
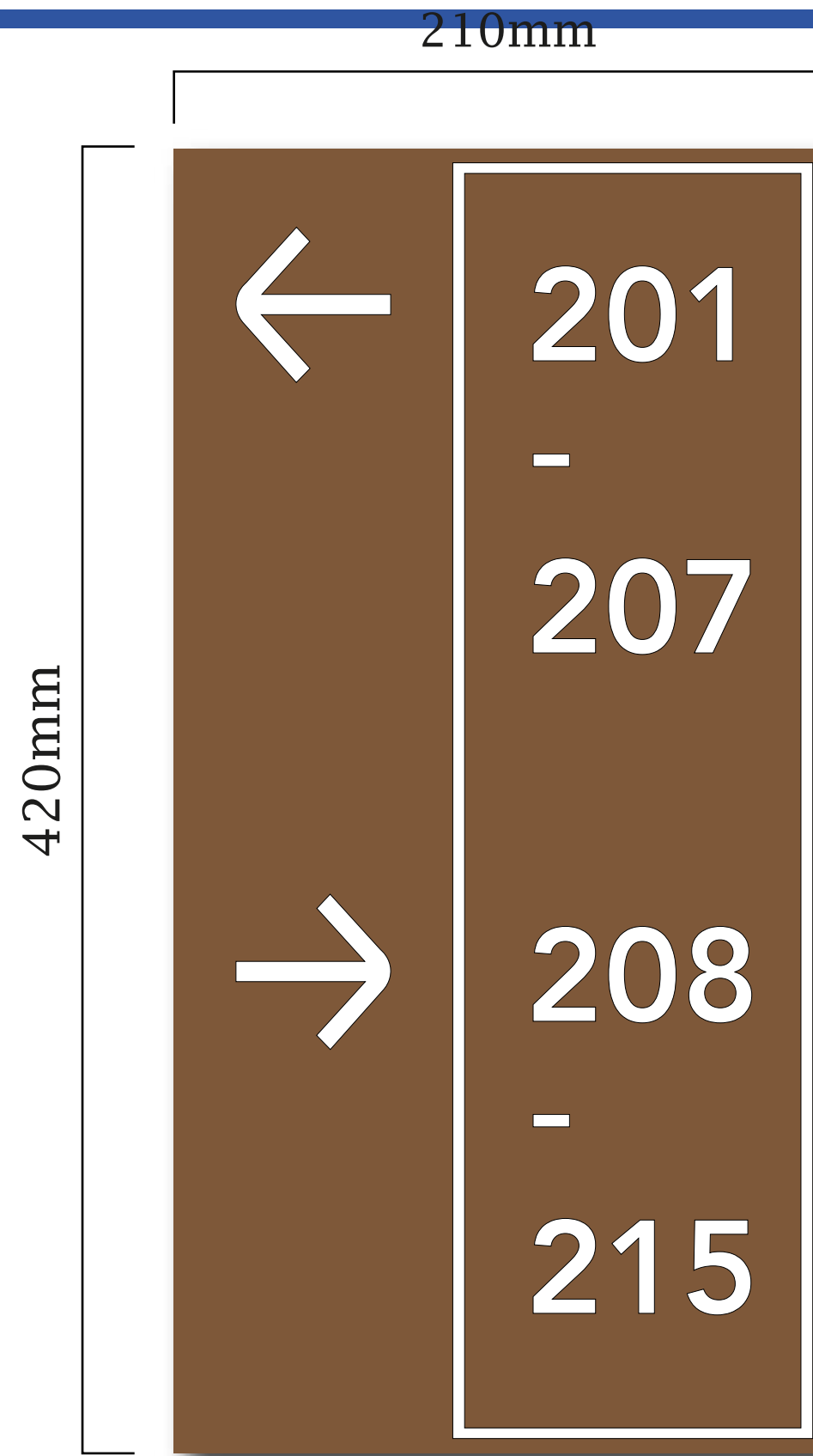

A photograph of a modern residential building with a mix of wood and grey siding, balconies, and large windows. In the foreground, there is a landscaped courtyard with a paved walkway, greenery, and a wooden bench. The sky is blue with light clouds.

# **RESIDENTIAL BUILDING PROJECT**

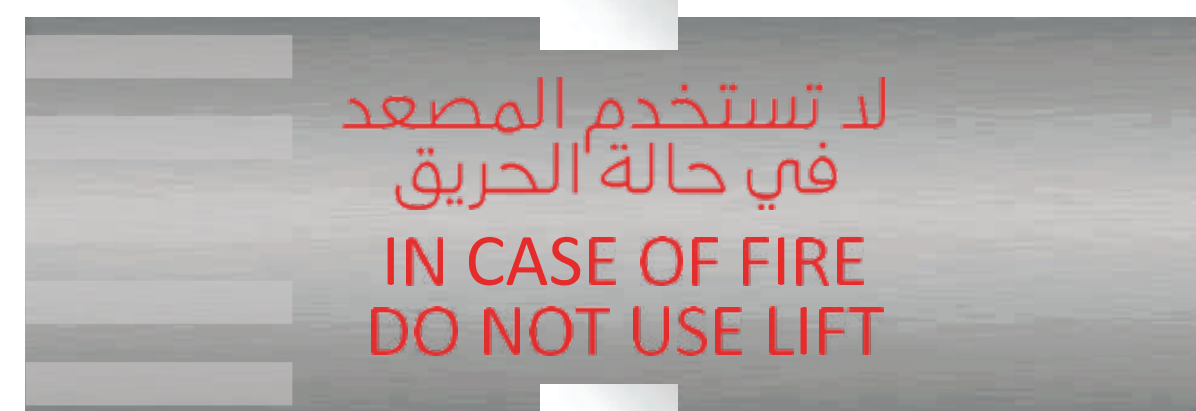

**AZIZI AL SHAMANDI AND PROGRESS**

(BUILDINGS 10,11,12,13,14,15)

(BUILDINGS 1,3,4,5,6,7,9,16,17,18,19)

# AL FURJAN

## RESIDENTIAL BUILDING PROJECT INTERNAL / CAR PARKING SIGNAGE

ELECTRICAL ROOM    غرفة الكهرباء



السلالم    2  
STAIR    

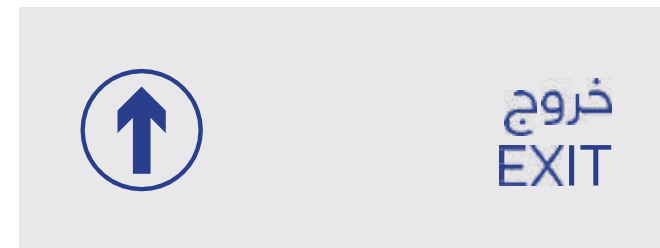

الطابق السفلي 1  
BASEMENT 1

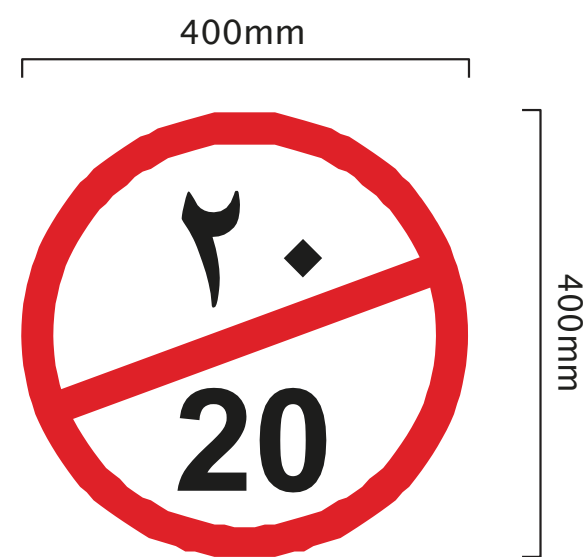

NOTE: FIXING WITH SCREW





A blurred background image of an office setting. In the foreground, a wooden desk holds a laptop, a pen, and a white coffee cup on a saucer. In the background, several people are standing and talking, their figures softened and out of focus. The entire scene is framed by a thin brown border.

# **OUR CLIENTS**

# OUR CLIENTS

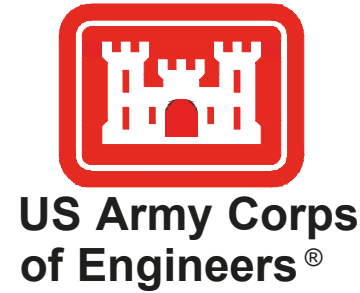



# ORGANIZATIONAL CHART & CV'S



# PRODUCTS ORGANIZATIONAL CHART

Here are the people responsible for making Tech Craft one of the fastest growing Signage & Digital Printing services in the UAE.

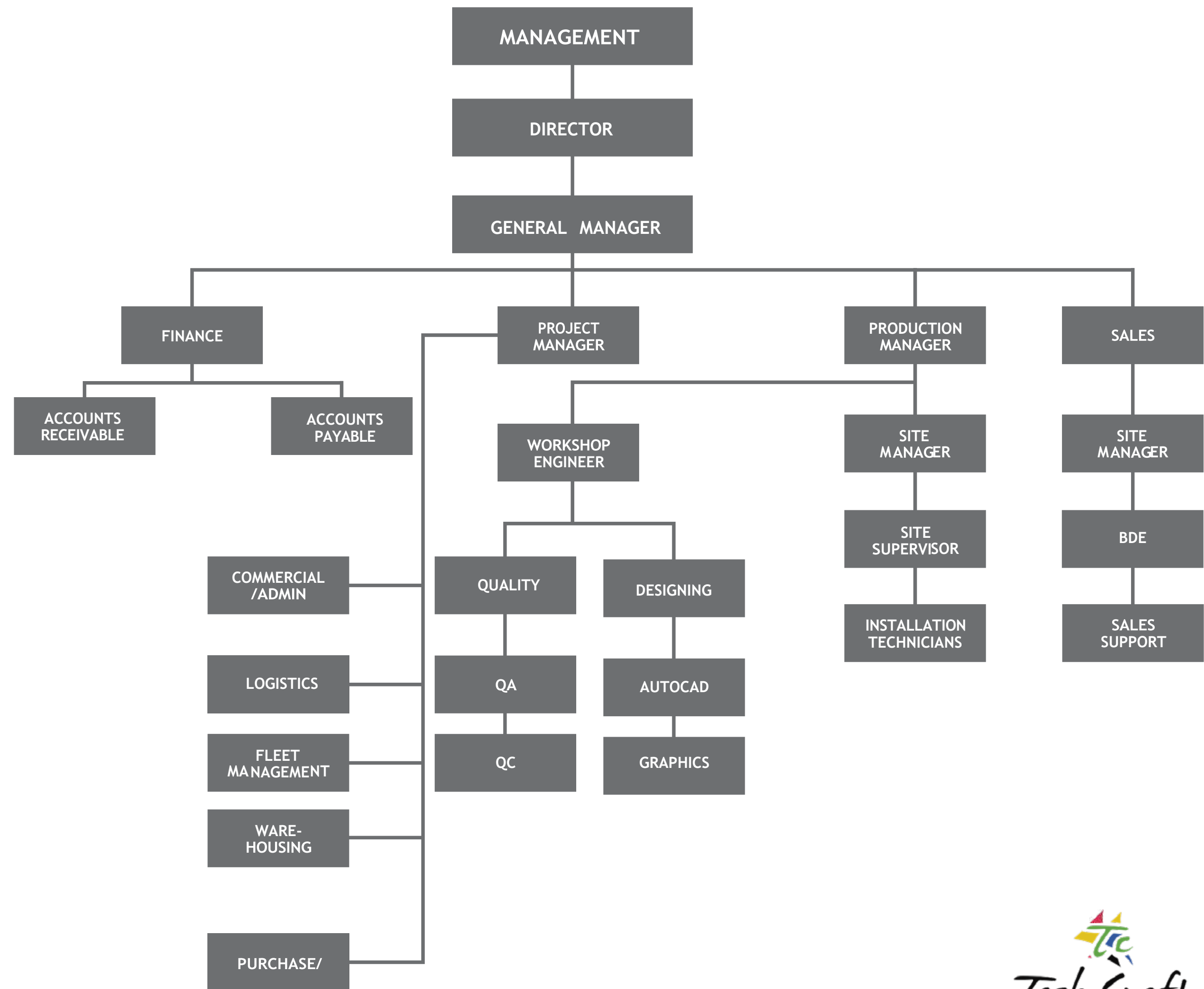

## CURRICULUM VITAE

Name : RAJEEV P. NAMBIAR  
Position : General Manager  
Academic : Bachelor of Technology (Mech)  
MBA, APICS (USA), Chartered Engineer

### INDUSTRIAL EXPERIENCE – 35 yrs. Experience

- ❖ Machine Building using steel, Stainless Steel involving Fabrication, Machining assembly and Testing & Commissioning in Industries like Steel Mill, Cement, Mining, Refractory, Space Research and Defense.
- ❖ Building pressure vessels and heat exchanger for Thermal & Nuclear Power Industries.
- ❖ Structure for Space Industries.
- ❖ Aluminium and Glazing work for High-Rise Buildings involving Aluminium Fabrication, Steel Fabrication and Stainless Fabrication.

### Experience in ISO 9001, 14001, 18001, Standard's Implementation and Maintenance

#### Position Handled Organization Wise:

Tech Craft Metal Industries	-	General Manager
Bin Lahej Aluminium	-	General Manager
BECON Aluminium	-	General Manager
Bosco Aluminium-Sharjah	-	Project Manager
Lloyds Steel Industries, India	-	Project Manager
Hari Machines Ltd.	-	Production Manager

## In the name of God most Merciful, most Gracious

### **Personal Data:**

- Name : ABEER SEDDIQ AHMED
- Date of Birth : 08/10/1979
- Religion : Muslim
- Marital Status : Single
- Telephone No : 056-411-3796
- Email : abeer@techcraft.tech
- Valid License : UAE Driving License

### **Objective:**

To establish a successful career in the field of Marketing and Advertising in a dynamic organization that provides a venue for growth opportunities both professional and personal.

### **Qualifications:**

- Being able to communicate efficiency with clients
- Fast learner and can easily cope up with the environment
- Persistent and determined
- Eager to learn and hard working.

### **Educational Attainment:**

- Bachelor of Political Science
- Media & Public Relation Diploma
- Master of Diplomatic Studies
- Feasibility Studies & Marketing Course

## **Work Experience:**

Experienced as a Marketing Manager with a demonstrated history of working in the marketing and advertising industry. Skilled in Marketing Management and Advertising. Strong marketing professional with a Bachelor of Political Science & Diploma in Media and Public Relations focused in Political & Media from Alnilin University & Sudan University

## **Responsibilities:**

- Marketing clients and arrange meeting with them (Negations/ Closing deals/ Payment follow up)
- Worked to tight targets as specified by the Management
- Preparing internal procedures for Sales & Marketing
- Team to provide a better service for clients.

## CURRICULUM VITAE

Name : SOUMYA KURIAKOSE  
Position : Production Manager  
Academic Qualification : Bachelor of Engineering (Civil)  
M. Tech (Structural)

### INDUSTRIAL EXPERIENCE – 10 Years

TECH CRAFT METAL - 2 years - Jotun Logo Tower  
G+15 Residential Bdlg.

#### THOMAS BENNET STEEL LLC

Projects:

- Bay Gate Roof Structure involving 180 Metric Tons of Steel Structure
- Carbon Steel Column Cladding Structure for King Abdulla Financial District – 300 Metric Tons
- Cladding Work for Concourse 3 at Dubai Airport

#### SIMEE INTERCON

- Marbles and its support structure for:
  - First Gulf Bank Head Quarter
  - Atlantis Palm Jumeirah
  - Villas & Residential Building

#### BLUE RHINE INDUSTRIES

Structure and Signages for Projects Involving Industries and Services for

- Hospitality
- Residential
- Leisure & Entertainment
- Retail

**Software Skill – Stad Pro, Tekla, Autocad**

## **CURRICULUM VITAE**

Name : PRESTON DSOUZA  
Position : Asst. Estimator  
Academic Qualification : Bachelor of Engineering (Mech)

### **INDUSTRIAL EXPERIENCE – 4 Years**

TECH CRAFT ADVERTISING & SIGNS LLC - 2 years

#### Projects:

Complete Signage works for:

- Uptown Al Zahia Development Phase A&B (Sharjah)
- Residential apartment (B+G+14F+R) at Al Barsha Heights(Dubai)
- Expo Live- Canada pavilion, Welcome pavilion
- Annual Maintenance Contract for Mashreq Signage Works in various locations (UAE)
- AJ 420 – Schlumberger Ace Base Expansion(Abu Dhabi)

KAIZEN CNC CENTER PVT. LTD. - 2 years

- As a Quality Engineer in CNC manufacturing industry in India.

Software Skills – Autocad 2D & 3D, CATIA, Adobe Illustrator

## CURRICULUM VITAE

Name : ARUN PRABHU  
Position : Project Engineer  
Qualification : Diploma in Civil Engineering  
Industrial  
Experience : 12 Years

### INDUSTRIAL EXPERIENCE:

#### TECH CRAFT ADVERTISING & SIGNS LLC

- 4 years in Signages & Advertising Division as Site Engineer  
Dubai, UAE

#### RITHWIK ENERGIES POWER PVT LTD.

- A Hydel Power Project in Construction and Maintenance in India.

#### MAK TELECOM

- Preparation of Foundation and Erection of Tower Structure for Telecom in India.

#### UNITECH BUILDERS

- As site Engineer in Residential Building Properties in India.



# CURRICULUM VITAE

## SHARON ROSHAN LASRADO

☎ 00971-056 - 4113795(UAE)

Bur Dubai, Dubai, UAE

Email: [roshan@techcraft.tech](mailto:roshan@techcraft.tech)

### WORKING EXPERIENCE:

- ♣ 2016 - Up to present - Techcraft Advertising & Signs LLC (TAK Group) - Head of Signage Dept.
- ♣ June 2014 - 2016 Working as a designer at Dome Exhibition LLC, Dubai, UAE.
- ♣ July 2013 - May 2014 working as a designer and Site Supervisor at Mangalore Interior Company, India

### ACADEMIC QUALIFICATION

- ✓ 2011-2013 - BSC Interior Design & Decoration @ Manglore University
- ✓ 2008-2009 - Pre-University Education @ Karnataka Pre-University Board
- ✓ 2006-2007 - Karnataka Secondary Education Examination Board

### COMPUTER LITERACY:

- ❖ Photoshop
- ❖ Illustrator
- ❖ Autocad
- ❖ 3Dx Max
- ❖ Premier Pro

### PERSONAL PROFILES:

- ✓ Name : Sharon Roshan Lasrado
- ✓ Father's name : Felix Lasrado
- ✓ Date of Birth : 08/11/1991
- ✓ Nationality : Indian
- ✓ Religion : Roman Catholic
- ✓ Marital Status : Married
- ✓ Languages Known : English, Hindi

### Interest & Hobbies:

- Photography
- Sports & games
- Music
- Free hand drawing
- Gardening
- Making friends
- Creative Craft

# JAWAD YOUNAS

Graphic Designer, Videographer, Photographer and Marketing Personnel  
jawadyounas05@gmail.com +971507071291, +971521630063

It would be an immense pleasure to work in a creative environment where I can enhance my graphic designing and web designing skills and can polish my aptitude.

## PERSONAL INFORMATION

GENDER: MALE

NATIONALITY: PAKISTANI

**CURRENT RESIDENCE: DUBAI**

## EXPERIENCE

JANUARY 2019 (Currently Working)

**GRAPHIC DESIGNER**, Tech Craft advertising & Signs L.L.C, DUBAI

Softwares Used: Adobe Photoshop, Adobe Illustrator, Corel Draw, Adobe Premiere, Auto Cad, 3D Max

NOVEMBER 2016 - DECEMBER 2019

**GRAPHIC DESIGNER**, CREATIVE EYE MEDIA L.L.C, DUBAI

Softwares Used: Adobe Photoshop, Adobe Illustrator, Corel Draw, Adobe Premiere, Adobe 3D Max, Adobe Flash Player

JANUARY 2014 - JUNE 2016

**EVENT ORGANIZER**, J&N ADVENTURE CLUB, ISLAMABAD, PAKISTAN

Job Role: Lead Planer, Organizer and Marketing Personnel

JUNE 2015 - JUNE 2016

**GRAPHIC DESIGNER & EVENT PHOTOGRAPHER**, SAFA GOLD MALL, ISLAMABAD, PAKISTAN

Softwares Used: Adobe Photoshop, Adobe Illustrator, Corel Draw

## EDUCATION

JUNE 2011- JUNE 2015

**BACHELOR IN COMPUTER ARTS & MULTIMEDIA DESIGN**, FOUNDATION  
UNIVERSITY, ISLAMABAD, PAKISTAN

## MY PORTFOLIO

<http://jdproduction.strikingly.com/> (A link summarizing my graphic designing, animation, videography and photography projects)

<https://www.youtube.com/channel/UC9fl6mqJQlwWF7GVh5PBCfw> (My personal YouTube channel, where I provide tutorials of professional graphic designing softwares to thousands of subscribers worldwide)

<https://www.facebook.com/jdsproductionjawad/> (Some additional photography work)

<https://www.instagram.com/jdsproductionuae/> (Instagram link for photography samples)

## SPECIALITIES

- Posters Stationary Brochure Design
- Logo Design
- Banner Design
- Marketing
- Illustration
- Wedding Events Photography
- Web Designing
- Social Media Designing

## AWARDS

Media President of Foundation University, Islamabad during my Bachelor degree.  
Champion of several badminton competitions during University life.

## **Curriculum Vitae**

**HARIPRASAD RAI**

**Email:** [hariprasad.kajamunda@gmail.com](mailto:hariprasad.kajamunda@gmail.com)

**Dubai U.A.E**

**Phone no: 0557509127**

### **Job experience; 12 year experience as an HSE officer in Dubai**

**To excel as a Health, Safety and Environmental practitioner whose main objectives is to meet the global purpose of preventing accidents, eliminating hazards and by protecting environment at construction sites**

- ⦿ Creating effective procedures for the preparation and implementation of programs within the area of Construction safety and the environment in process.
- ⦿ Conducting Risk Assessment; implementing Health Safety Environment Management System and formulating Mutual Aid Scheme with simultaneously working contractors and sub-contractors.
- ⦿ Coordinating with execution team in Implementing Work Permit System.
- ⦿ Advising administration and supervising the Safety, Environment, Health & Security Systems at Temporary Rest Area Facility.
- ⦿ Investigating employee Health and Safety complaints; discusses findings and recommends possible solutions.
- ⦿ Acting as liaison with local regulatory agencies for the environmental program, ensuring submission of applicable monthly, quarterly & annual environmental reports.
- ⦿ Inspecting machinery, equipment and workplaces & ensuring suitable protective equipment, such as hearing protection, dust pollution protection, PPE are provided and is being used correctly.
- ⦿ Ensuring workplaces and workstations comply with health and safety legislation & investigating complaints, serious incidents and accidents. Submitting reports about the results of inspections and investigations and making its follow up.
- ⦿ Coordinating HAZOP Studies for modification, new process or changes in existing activities.
  
- ⦿ Imparting training to Managers, Supervisors, Contractors and Workers in the field of Environment, Health, Fire Prevention and Safety.

## **WORK EXPERIENCE ( COMPLETED AND ON GOING PROJECT )**

- 1 G+3P+25 RESIDENTIAL BUILDING JVC( ON GOING)**  
CLIENT: ALIMBEK PALVAN  
AUTHORITY: TRAKHEES, NAKHEEL
- 2 B+G+5 RESIDENTIAL BUILDING JVC ( ON GOING)**  
CLIENT: GREEN PROPERTIES  
AUTHORITY: TRAKHEES, NAKHEEL
- 3 G+2+19 CATCH RESIDENCY TOWER JVC ( ON GOING)**  
CLIENT: IGO REAL ESTATE DEVELOPMENT DUBAI  
AUTHORITY: TRAKHEES, NAKHEEL
- 4 G+3P+15 RESIDENTIAL BUILDING JVC DUBAI**  
**CLIENT: KHYBER INVESTMENT DUBAI**  
AUTHORITY: TRAKHEES, NAKHEEL
- 5 2B+G+15 PROJECT 2B+G+14+R RESIDENTIAL BUILDING AL FURJAN DUBAI**  
CLIENT: SATGURU HOLDINGS LIMITED  
AUTHORITY: TRAKHEES, NAKHEEL
- 6 G+7 RESIDENTIAL BUILDING SATWA DUBAI**  
CLIENT: MOHAMED AND OBAID AL MULLA LLC  
AUTHORITY: DUBAI DEVELOPMENT AUTHORITY
- 7 G+2 SAFA SCHOOL BUILDING ARJAN**  
CLIENT: SAFA SCHOOL MANAGEMET  
AUTHORITY: DDA
- 8 B+G+4 OFFICE BUILDING**  
CLIENT; JOURNALISTS ASSOCIATION  
AUTHORITY: DUBAI MUNICIPALITY
- 9 G+3 RESIDENTIAL BUILDING AL HAMRIYA DUBAI**  
CLIENT; MOHAMED AND OBAID AL MULLA LLC  
AUTHORITY: DUBAI MUNICIPALITY
- 10 G+M+5 RESIDENTIAL BUILDING AL SOUK AL KABEER DUBAI**  
CLIENT; MOHAMED AND OBAID AL MULLA LLC  
AUTHORITY; DUBAI MUNICIPALITY
- 11 NORTH BEACH DEVELOPMENT PROJECT, JUMEIRA BEACH HOTEL DUBAI**  
CLIENT: SALALAH FACILITIES MANAGEMENT SEVICES
- 12 AW ROSTHAMANI WORKSHOP FACILITIES DUBAI INDUSTRIAL CITY DUBAI**  
CLIENT: AL ROSTAMANI HOLDING S
- 13 AL ROSTAMANI COMMERCIAL AND RESIDENTIAL INVESTMENT VILLA JUMEIRA**  
CLIENT: AL ROSTMANI HOLDINGS
- 14 G+1 SULTAN VILLA AL BARSHA THIRD**  
CLIENT: SULTAN ALI SULTAN HILAL AL SUBOOSI  
CONSULTANT: ERGA PROGRESS ENGINEERING CONSULTANT  
AUTHORITY; DUBAI MUNICIPALITY
- 15 G+1 PRIVATE VILLA AL WARQAA**  
CLIENT: MOHAMMAD SALEH MALIK  
CONSULTANT: ARR ENGINEERING CONSULTANCY
- 16 G+4+R LABOUR ACCOMADATION JABEL ALI**  
CLIENT: PROSCAPE LLC

CONSULTANT: RENAISSANCE ENGINEERING CONSULTANCY  
**17 PROPOSED G+1 4UNITS AND G+1 3UNITS AL FURJAN TOWN HOUSE**  
CLIENT: MR IMTAWA ALI SULTAN HILAL AL SUBOOSI MR MEHER SHAMAMIT  
CONSULTANT: ERGA PROGRESS ENGINEERING CONSULTANT  
**18 PROPOSED G+1 5UNITS AND G+1 5UNITS AL FURJAN TOWN HOUSE**  
**CLIENT: MR IMTAWA ALI SULTAN HILAL AL SUBOOSI MR MEHER SHAMAMIT**  
CONSULTANT: ERGA PROGRESS ENGINEERING CONSULTANT  
**19 PROPOSED B+G+1 INVESTMENT VILLA JUMEIRA**  
CLIENT: MR MOHAMMAD AL TAYER  
CONSULTANT: ARR ENGINEERING CONSULTANCY  
**20 PROPOSED G+4 LABOUR ACCOMADATION**  
CLIENT: MR AHMAD SHARAF  
CONSULTANT: AL JASSIM ENGINEERING CONSULTANT

### **EDUCATION AND QUALIFICATION**

Diploma in health and safety engineering

NEBOSH IGC

**TRAKHEES ECSR-1-SARS. ID SARS RNW-2761**

### **PERSONAL INFORMATION**

Name	Hariprasad Rai Kajamunda
Age	39 Years
Sex	Male
Date of birth	07/04/1983
Nationality	Indian
Marital Status	Single
Languages Known	English, Kannada, Hindi, Tulu and Malayalam.
Email	harishshetty101@yahoo.com

### **DRIVING LICENSE**

Driving license of **U.A .E**  
License no                   **115422**  
Date of issue                **24/11/2009**  
Date of expiry               **23/11/2024**

# CURRICULUM VITAE

## **BALDEV SINGH**

☎ 00971-055 3943300 (UAE)

☎ 0091-99-14778991 (INDIA)

Dubai, UAE

Email: [baldev.production@techcraft.tech](mailto:baldev.production@techcraft.tech)

## **OBJECTIVE**

Seeking a challenging career in an esteemed organization where my talents can be utilized for the growth of the company as well as self in an environment where team player role is significant and to be best, be considered as an asset by employer. Learn, gain and implement.

## **WORKING EXPERIENCE:**

- ♣ Working as Signage Supervisor at Techcraft Advertising & Signs, LLC from 2018 up to date.
- ♣ 3 years as Signage Supervisor at Strips Advertising Signage, LLC – Dubai, UAE.
- ♣ Working as a 3G Welder (Tig, Mig, and Arc) Letter Molding and Fabricator With Galaxy Metal Industries LLC in Dubai-UAE since last 2 years to till date.
- ♣ 5 years working experience as a Welder & Fabricator, Letter Molding with Thomas Bennet Gulf LLC in Dubai-UAE.
  - ✓ 1 years working experience in Jordan Under Thomas Bennet Gulf LLC in Dubai-UAE.
- ♣ 5 years working experience as a 3G Welder (Tig, Mig, and Arc) & Fabricator in India.

## **Working Strength**

- ✓ Extensive experience in 3G welding (Arg, Mig & Tig), Letter Molding and fabricating
- ✓ Skilled in drawing and design techniques, Skilled in operating power and hand tools
- ✓ Knowledge of working with welding tools and equipment
- ✓ Strong knowledge of all types of welding processes
- ✓ Great understanding in reading and interpreting blueprints and engineering drawings
- ✓ Skilled in cutting steel plates in all shapes and sizes as required
- ✓ Excellent expertise in welding and assembling all types of metals
- ✓ Maintain and follow up safety rules as per construction standard.

## **PERSONAL PROFILES:**

- ✓ Name : Baldev Singh
- ✓ Father's name : Mohender Singh
- ✓ Date of Birth : 15/12/1986
- ✓ Nationality : Indian
- ✓ Religion : Sikh
- ✓ Marital Status : Married
- ✓ Languages Known : English, Hindi and Punjabi

## **PASSPORT DETAILS:**

- ✓ Passport No : R 2337266
- ✓ Date of Issue : 23/03/2017
- ✓ Date of Expiry : 22/03/2027
- ✓ Place of Issue : Dubai
- ✓ Visa Status : Employment Visa

# LIST OF MACHINERIES

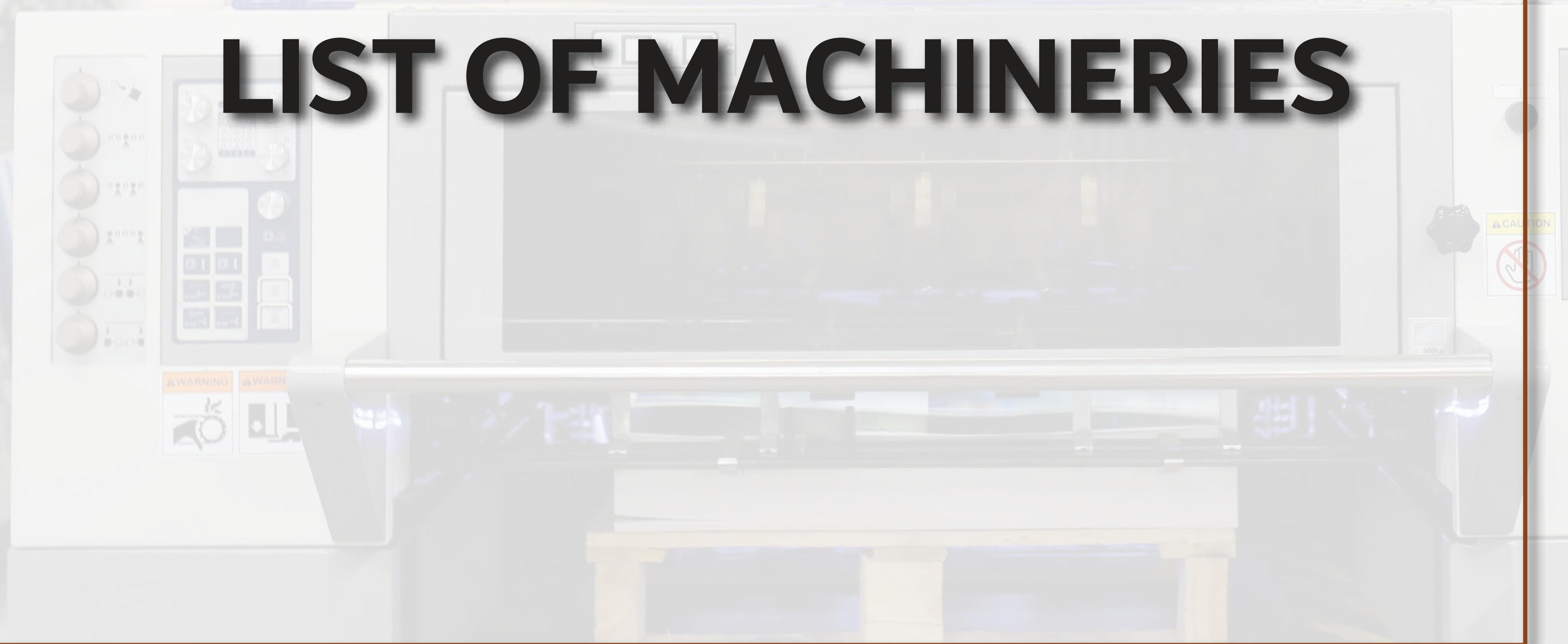



# LIST OF MACHINERIES



NAME	ORIGIN	QTY
Air Blower	China	1
Air Buffing Machine	China	1
Air Sander Belt	China	3
Aluminum Cutting Machine	Japan	2
Angle Drill Machine	Japan	1
Arc Welding Machine	Finland	3
Bench Cutter	China	1
Bench Cutter (Mounting Type)	Japan	1
Bench Drilling Machine	Taiwan	1
Buffing Machine (Grinder)	China	2
Charger Drills	Japan	4
CNC Router	Germany	2
Compressor	China	2
Cordless Drill	Japan	3
Dryer Rack	Korea	5
Dry Booth	Korea	1
Grinding Machine	Japan	7
Hand Cutter	Japan	1
Hand Router Heavy Duty	Japan	4
Hand Router Light Duty	Japan	2
Heater	Japan	4
Heavy Duty Grinder	Japan	1
Hot Air Blower	China	2
Hydraulic Aluminum Machine	China	1
<b>HP Letex 370</b>	Japan	1
<b>Epson Sure Color</b>	Japan	1

NAME	ORIGIN	QTY
Jigsaw Machine	Japan	2
Lamination Machine	China	2
Digital Print Machine	Japan	3
Laser Machine(Acrylic)	China	1
Laser Machine(Metal)	Swiss	1
Letter Bending Machine	China	2
Magnetic Drill Machine	Japan	1
Mig Welding Machine	Finland	6
MS Cutting Machine	Japan	1
Nail Gun	Japan	2
Paint Buffing Machine	Japan	1
Paint Gun	Korea	1
Plotter Machine	Japan	2
Power Drill	Japan	9
Profile Cutting Machine	Turkey	1
Sanding Machine	Japan	3
Sanding Machine (Air)	China	4
Shearing Machine	Japan	1
Sheet bending machine	Turkey	3
Soldering Machine	Turkey	2
Spray Booth	Korea	1
Stapler Gun	Japan	1
Warga Cutter	China	1
Wood Cutting Machine	Japan	1
<b>Canon UV Flatbed</b>	Germany	1
<b>Acrylic Buffer Machine</b>	China	1
<b>Cnc Lasser</b>	China	1

# LIST OF MACHINERIES

---

## SAW SIMCO MACHINE

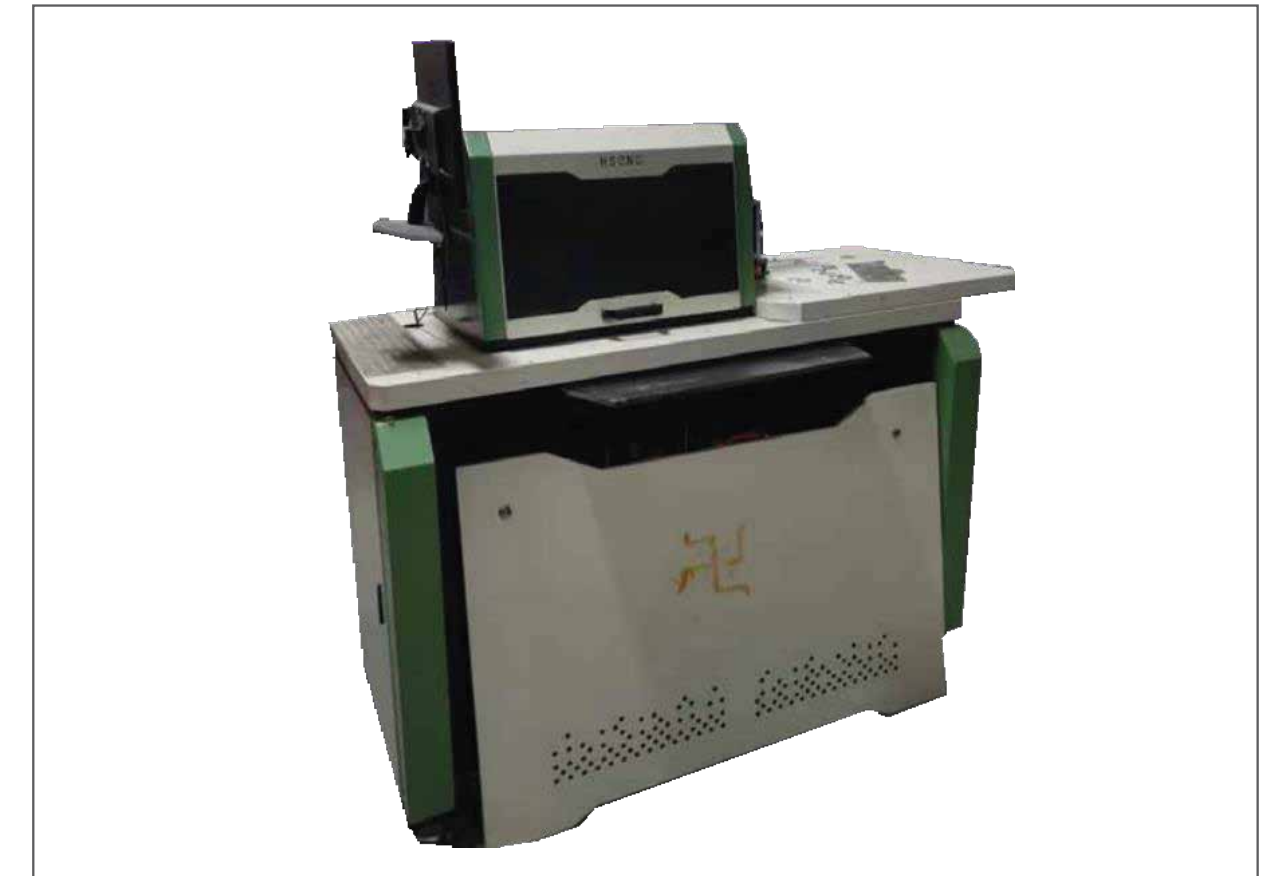
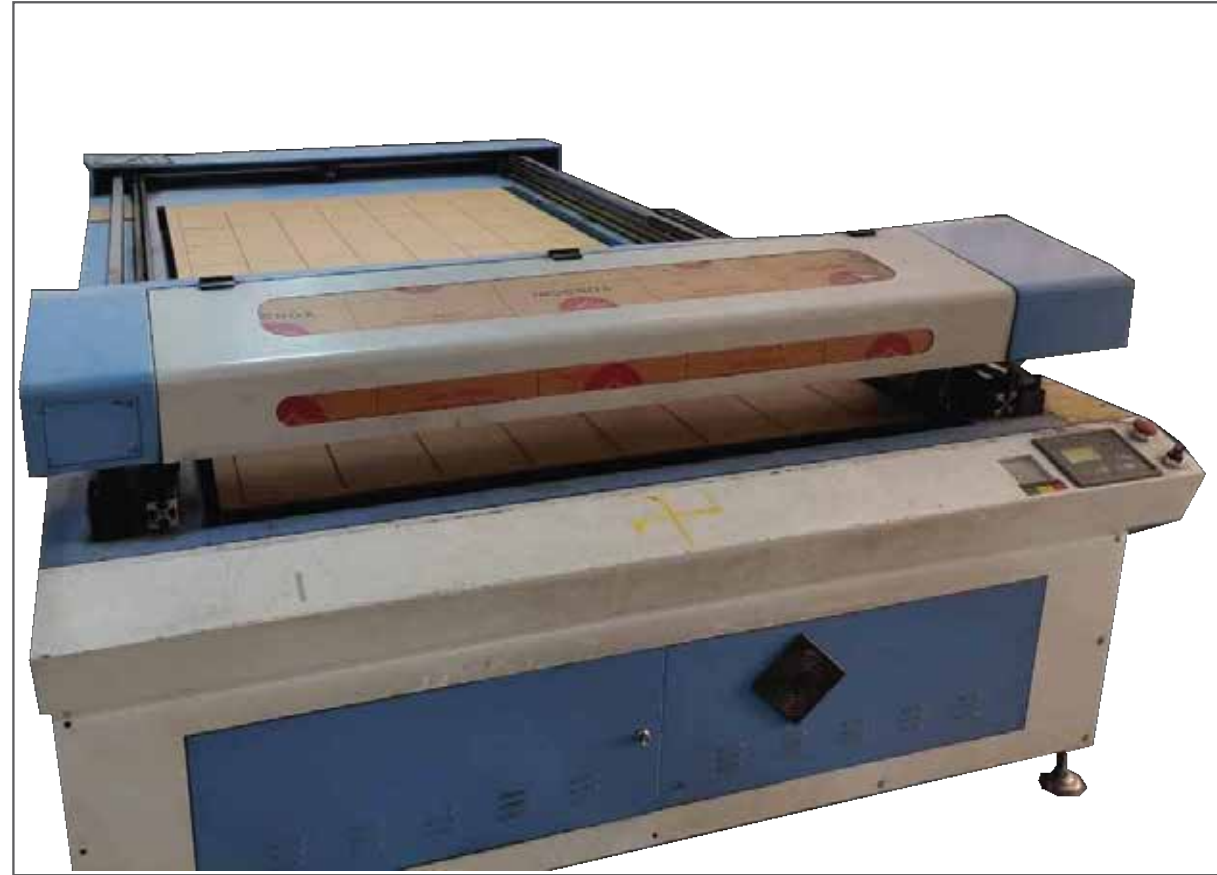



# **COMMERCIAL LICENCE**



## رخصة تجارية Commercial License

### تفاصيل الرخصة / License Details

License No.	758008	رقم الرخصة
Company Name	TECH CRAFT ADVERTISING & SIGNS L.L.C	اسم الشركة تك كرافت ادفرتايزنج اند ساين ش.ذ.م.م.
Trade Name	TECH CRAFT ADVERTISING & SIGNS L.L.C	الإسم التجاري تك كرافت ادفرتايزنج اند ساين ش.ذ.م.م.
Legal Type	Limited Liability Company(LLC)	الشكل القانوني ذات مسؤولية محدودة
Expiry Date	03/05/2023	تاريخ الإصدار 04/05/2016
D&B D-U-N-S @	0	رقم الرخصة الام 758008
Register No.	1227452	عضوية الغرفة 268644
	رقم العالمى 0	Main License No.
	رقم السجل التجارى 1227452	DCCI No.

### الاطراف / License Members

Share / الحصص	Role / الصفة	Nationality / الجنسية	Name / الاسم	No./رقم الشخص
	Manager / مدير	United Arab Emirates / الامارات	ذياب ناصر سالم ناصر الخليفي THEYAB NASSER SALEM NASSER ALKHLAIFI	203839

### نشاط الرخصة التجارية / License Activities

Distribution of Advertising Materials & Samples	توزيع المواد الاعلانية والعينات
Advertisement Designing & Producing	خدمات الدعاية والإعلان لإنتاج وتصميم الإعلانات
Advertising Billboards Contracting	مقاولات تركيب اللوحات الاعلانية
Calligraphers & Painters	خدمات الخط والرسم

### العنوان / Address

Phone No	تليفون	P.O. Box	487131	صندوق بريد
Fax No	فاكس	Parcel ID	597-732	رقم القطعة
Mobile No	هاتف مترك			مستودع رقم 8 ملك طلال حميد عبدالله بالهول-مجمع دبي للاستثمار
				البريد الإلكتروني / Email

### الملاحظات / Remarks

Print Date 29/04/2022 11:00 تاريخ الطباعة Receipt No. 14382019 رقم الإيصال



يمكنك الآن تجديد رخصتك التجارية من خلال الرسائل النصية القصيرة، أرسل رقم الرخصة إلى 6969 (دو/اتصالات) للحصول على اذن الدفع.  
Now you can renew your trade license by sending a text message (SMS). Send your trade license number to 6969 (Du/ Etisalat) to receive payment voucher.

Get FREE access to Zoho One for the first year  
احصل على زوهر ون مجاناً للسنة الأولى  
Zoho.com/det



وثيقة إلكترونية معتمدة وصادرة بدون توقيع من دائرة الإقتصاد والسياحة في دبي. لمراجعة صحة البيانات الواردة في الرخصة يرجى مسح رمز الاستجابة السريعة  
this is a certified e-document issued without signature by the department of Economy and Tourism .Kindly Scan the QR Code to Verify the certificate



رخصة صناعية  
Industrial License

تفاصيل الرخصة / License Details

License No.	899715	رقم الرخصة
Company Name	TECH CRAFT METAL INDUSTRIES L.L.C	اسم الشركة
Trade Name	TECH CRAFT METAL INDUSTRIES L.L.C	الإسم التجاري
Legal Type	Limited Liability Company(LLC)	الشكل القانوني
Expiry Date	13/09/2022 تاريخ الإنتهاء	تاريخ الإصدار
D&B D-U-N-S ®	0 الرقم العالمي	رقم الرخصة الام
Register No.	1506846 رقم المسجل التجاري	عضوية الغرفة
Issue Date	14/09/2020	تاريخ الإصدار
Main License No.	899715	رقم الرخصة الام
DCCI No.	344799	عضوية الغرفة

الاطراف / License Members

Share / الحصص	Role / الصلة	Nationality / الجنسية	Name / الاسم	No. / رقم الشخص
	Manager / مدير	India / الهند	براڤين كومار امارنات	458537

Beneficiary Owner consent of this license has been signed on 23/08/2021. For more information or to know the Beneficiary Owner please visit any DED service center or DED eServices website.

تم توقيع إفادة المستفيد الحقيقي لهذه الرخصة بتاريخ 23/08/2021. للمزيد من المعلومات أو لمعرفة المستفيد الحقيقي يرجى التكرم بزيارة مراكز الخدمة أو الخدمات الإلكترونية التابعة لدائرة التنمية الاقتصادية.

نشاط الرخصة التجارية / License Activities

Building Metal Products Manufacturing

صناعة الاثغال المعدنية للمباني

Phone No تليفون  
Fax No فاكس  
Mobile No 971-50-5533395 هاتف متحرك

Address / العنوان  
P.O. Box صندوق بريد  
Parcel ID 597-732 رقم القطعة  
مستودع رقم 08 ملك لطلال حميد عبدالله المنطقة : مجمع دبي للاستثمار الثانية - بر دبي

Email / البريد الإلكتروني

الملاحظات / Remarks

Print Date 29/08/2021 10:58 تاريخ الطباعة

Receipt No. 14032309 رقم الإيصال



يمكنك الآن تجديد رخصتك التجارية من خلال الرسائل النصية القصيرة، أرسل رقم الرخصة إلى 6969 (دو/اتصالات) للحصول على ائق الدفع.  
Now you can renew your trade license by sending a text message (SMS). Send your trade license number to 6969 (Du/ Etisalat) to receive payment voucher.

Get FREE access to Zoho One for the first year  
احصل على زوهو ون مجاناً للسنة الأولى







Zoho.com/DED

الإمارات  
THE EMIRATES

وثيقة إلكترونية معتمدة وصادرة بدون توقيع من دائرة التنمية الاقتصادية. لمراجعة صحة البيانات الواردة في الرخصة برجاء زيارة الموقع [www.dubaied.gov.ae](http://www.dubaied.gov.ae)  
Approved electronic document issued without signature by the Department of Economic Development. To verify the license kindly visit [www.dubaied.gov.ae](http://www.dubaied.gov.ae)

A blurred background image showing two business people shaking hands over a laptop. The laptop screen displays various charts and graphs, including a pie chart and a bar chart. The scene is brightly lit, suggesting an office environment.

# **PREVIOUS APPROVALS**

					
<b>MINA ZAYED FISH MARKET – MAIN WORKS</b>					
<b>Drawing Transmittal</b>					
To :	M/s. ARCADIS	Transmittal			Date
Attention :	Mr. Revikumar P A	MZ-04-00001-01-11-AR-ACSB-WR-000060[00]			23-Oct-2021
Cc :	M/s. MODON PROPERTIES				
<b>TYPE OF DOCUMENT</b>				<b>Reference List</b>	
<input type="checkbox"/> Certificate	<input type="checkbox"/> Schedules	Specification	:		
<input type="checkbox"/> Reports/ MST	<input type="checkbox"/> Charts & Procedures/Plan	BOQ Reference	:		
<input type="checkbox"/> Calculation	<input checked="" type="checkbox"/> Others (Warranty)	Drawing Ref:	:		
<b>Attachments of Document</b>					
<input type="checkbox"/> Technical Data	<input type="checkbox"/> Test Reports	<input type="checkbox"/> Copy of Specification	<input type="checkbox"/> Letters/ Guarantees		
<input type="checkbox"/> Compliance Statement	<input type="checkbox"/> Sample Tag	<input type="checkbox"/> Certificates	<input checked="" type="checkbox"/> Others (Warranty)		
S. No	Document/Drawing No.	Rev	Description	Discipline	Issued for
1	MZ-04-00001-01-11-AR-ACSB-WR-000060	00	Draft Warranty Certificate for External Signages	Arch.	Approval
Projects Director : Haitham Abdel Kader				Date: 23-Oct-2021	
Consultant Comments:				Approval Status (By Consultant)	
<p style="color: red;">Warranty period should be as per ADM regulations (10 years) and dated from issue of TOC. Contractor to state the following in the warranty letter.</p> <p style="color: red;">1.Warranty Commencement Date (from TOC date / date to be mentioned clearly)</p> <p style="color: red;">2.Warranty Call-out Coverage</p> <p style="color: red;">Submit the copy of warranty incorporating comments and the TOC date for final verification</p>				<input type="checkbox"/> Code A: Approved <input type="checkbox"/> Code B: Approved with Comments <input checked="" type="checkbox"/> Code C: Not Approved / Revise & Resubmit <input type="checkbox"/> Code D: For Information	
For Consultant		MM	Signature: MM	Date	
Consultant RE's Comments					
For Consultant			Signature:	Date	
Amana Receiver's			Signature & Stamp	Date	

[ **MATERIAL SUBMITTAL FORM** ]

<b>PROJECT TITLE:</b>	<b>AL ZAHIA NORTH HUB LANDSCAPING PACKAGE (PHASE A &amp; B) - LANDSCAPING TO ROADS 1 &amp; 3</b>		
<b>CONSULTANT:</b> M/s.Cracknell	<b>EMPLOYER:</b> M/s. Majid Al Futtaim Properties		
<b>Submittal Ref. No.</b> GM-P179-AZOL-LS-MTS-HL-023	<b>Date:</b> 31-Jan-2022	<b>Rev:</b> 02	
Previous Submittal Ref. No: NIL	Dated: 08 Dec 2021		
Originator: Green and More Landscape Gardening LLC	Sign of Originator:		
Submittal Discipline:	<input type="checkbox"/> STR <input type="checkbox"/> ARCH <input type="checkbox"/> ID <input type="checkbox"/> EL <input type="checkbox"/> MECH <input type="checkbox"/> HVAC <input type="checkbox"/> PL <input type="checkbox"/> FF <input type="checkbox"/> INFRA <input checked="" type="checkbox"/> LS <input type="checkbox"/> HSE <input type="checkbox"/> OTHERS .....		

**Material Detail**

Specified

Alternative

**List of Enclosures**

<b>Item Description</b>	<b>Signage Works, including</b> - 3mm thk Opal White Acrylic(TLI to illuminate - Alum. Square Tube(waterjet cut with petal pattern; Color RAL 8022, Screen Printed-Text&Symbol, - 25x25x3mm Aluminum SHS - 300W Converter(1DF300CV-S12V1) and Led Light Agilight PRO 160 - M8x200 Chemical Bolts and other fixing accessories.	(Tick the Related Box) <input checked="" type="checkbox"/> Vendor's Technical Literature
<b>Specs. Reference</b>	CLL-SIG-DWG-P105-SS-00-7213	<input checked="" type="checkbox"/> Compliance Statement
<b>BOQ Reference</b>	Bill.No.4 & 4.1 SIGNAGE AND WAYFINDING - ROAD 1 & 3	<input checked="" type="checkbox"/> Previous Test Results
<b>Drwg. Reference</b>	CLL-SIG-DWG-P105-SS-00-7213	<input type="checkbox"/> Copy of the Related Specs.
<b>Material Specified</b>		<input checked="" type="checkbox"/> List of Previous Projects Done
<b>Material Proposed</b>		<input checked="" type="checkbox"/> Samples
<b>Manuf/Local Supplier</b>	Techcraft	<input type="checkbox"/> BREEAM
<b>Reason for Alternative</b>		<input checked="" type="checkbox"/> Others (Specify):
<b>Remarks</b>		Previous Approval, Company Profile, Draft Warranty, Trade License

**Main Contractor Statement:**

We certify that the material submitted herewith has been reviewed in detail and is in compliance with the contract drawings and specifications except as otherwise stated hereabove.

Main Contractor Signature:

Date: 31-Jan-2022

Lead Consultant Received:

Date:

**Lead Consultant's Comments:**

Top to be closed same as the 4 sides (aluminum black 8022).  
Symbol color to match the Phase 4 signage.  
~~Ensure the Arabic translation is correct.~~  
Accessories must be SS.  
Refer to images for petals orientation of 4 sides.

Gerry ocampo  
10.02.22

Elevations



- Status A - Approved  
 Status B - Approved As Noted  
 Status C - Revise & Resubmit  
 Status D - Rejected

Lead Consultant Signature:

Date:

Client Representative Signature:

Date:

Contractor Received Signature:

Sub-Contractor Received Signature:





EC01 - VERTICAL FARMING ON PLOT NO. AC5 - 17, DUBAI SOUTH, UAE

MATERIAL INSPECTION REQUEST

MIR Reference : DJ-282-P-QC-MIR-0293-00

Originator of MIR : QA/QC Dept Date : 23-Dec-21

Location of storage/Insp : At site Insp.Date : 24-Dec-21

Authorised Sign : \_\_\_\_\_ Insp.Time : 11:00 AM

**Type of Material**

Architectural  Structural  Electrical  Mechanical  HVAC

Infrastructure  Landscape  Interior Design  Others (Specify).....

Material Details		Manufacturer /Supplier Details	
Material Description	: English Letar 7miter one set	Manufacturer	: Tech Craft Advertising&Signs L.L.C
Material Submittal Ref	: DJ-282-P-CPS-EN-MAT-0159-01	Manufacturer Date	: 20-Dec-2321
Material Approval Code	: B	Batch No	: -
Specification Ref	:	Country of Origin	: UAE
Drawings Ref	:	Supplier	: Tech Craft Advertising&Signs L.L.C
BOQ Ref	:	Delivery Note No	: 4,731
Area of Use	: At site	Delivery Date	: 23-Dec-21
Storage Requirements	:	Quantity Delivered	: As per delivery note

**Attachments:**  Contractor's QA/QC Checklist  Delivery Note  Material Submittal  Others (Specify) \_\_\_\_\_

Contractor's QA/QC Engineer Sign: \_\_\_\_\_ Date: 23-12-21

Contractor's PM Sign: \_\_\_\_\_ Date: \_\_\_\_\_

Consultant Received Sign: \_\_\_\_\_ Date: \_\_\_\_\_



Consultant Engineer's comments

For all signage details provide contouring test reports along with paint information

Inspected By: Date: 26/12/21

**Resident Engineer's Comments:**

Code A - Approved

Code B - Approved As Noted

Code C - Not Approved, Resubmit

Code D - Information,Record

Code E - Incomplete, Resubmit

RE Sign : Date : 26/12/21

Contractor Received Sign : \_\_\_\_\_ Date : \_\_\_\_\_

Project : AZUT Club House &KIOSK - At Muwaileh, Sharjah UAE	Submittal No. : UNEC/J300/CH/AR/MS-032-R3
Contract No : J300	Sample tag : 32-R3
Contractor : United Eng. Const. Gen. Cont. & TR. LLC (UNEC)	Date : 25/09/2021
Client : MAFP & Sharjah Asset Management	Title : Signage Aluminium (3mm Thickness)
Lead Consultant : Engineering Consultants Group	Discipline :
Product Name : Signage Aluminium With Matt Finish Paint (3mm Thickness)	Sample Provided : Aluminium (3mm Thickness)
Manufacturer : Tech Craft Advertising & Signs LLC	Supplier : Tech Craft Advertising & Signs LLC

To : Al Zahia Uptwon at Muwaileh, Sharjah - UAE

From: M/s UNEC

Eng. Ammar Al Saqer

Reviewing Lead Consultant Signature : \_\_\_\_\_  
 Date : \_\_\_\_\_

Signature :   
 Date : \_\_\_\_\_

**SAMPLE STATUS**

- Approved
- Approved As Noted
- Revise and Resubmit
- Rejected

**LEAD CONSULTANT'S SIGNATURE**

**CLIENT'S SIGNATURE**





ECG Signature :   
 Date : 13/10/2021

MAF PM Signature : \_\_\_\_\_  
 (If required)  
 Date : \_\_\_\_\_

**SAMPLE PHOTOS**

Refer to the attached photos for approved samples

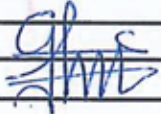

Client 		Consultant 		Main Contractor 	
Project Name: Bloom Heights		Plot No.: JVC15SHRA200		Project No.: P224	
<b>APPROVAL OF DOCUMENT SUBMITTAL</b>					
To	Consultant		Rev. 0	Date: 08/10/2020	
Submittal No.	P224/OCC/DS/135				
Submittal Title	Signage Samples				
S. No.	Description	Type	Copies	Remarks	
1	Service Rooms Sign	Sample	1	FOR APPROVAL	
2	Level & Staircase Sign				
3	Entry Sign				
Subcontractor: M/s TechCraft Advertising & Signs, LLC					
We certify that the documents submitted herewith have been reviewed and are in conformance with the contract except as otherwise stated.					
Submitted by:	PM - Eng. Gaballah	Received By			
Reviewed by:	QA/QC Mng - Eng. Bakara	Date			
Date and Stamp:	08/10/2020	Date and Stamp			
Consultant review and Comments:					
① To comply with specs. and approved drawings ② To comply with authorities regulations and requirements ③ Detailed shop drawings to be submitted as per approved sample. ④ Proper installation shall be maintained. ⑤ Mock up to be installed for final approval ⑥ Warranty certificate to be submitted				<b>APPROVAL STATUS:</b> APPROVED: <input type="checkbox"/> APPROVED AS NOTED: <input checked="" type="checkbox"/> REVISE AND RESUBMIT: <input type="checkbox"/> REJECTED: <input type="checkbox"/> NOTED: <input type="checkbox"/> FOR INFORMATION: <input type="checkbox"/>	
CONSULTANT AUTHORIZED AGENT:		SIGNATURE:		DATE: 15-10-2020	
Qasem					
PROJECT MANAGER'S Comments:					
				<b>APPROVAL STATUS:</b> APPROVED: <input type="checkbox"/> APPROVED AS NOTED: <input type="checkbox"/> REVISE AND RESUBMIT: <input type="checkbox"/> REJECTED: <input type="checkbox"/> NOTED: <input type="checkbox"/> FOR INFORMATION: <input type="checkbox"/>	
PROJECT MANAGER'S AUTHORIZED AGENT:		SIGNATURE:		DATE:	
BLOOM Comments:					
				<b>APPROVAL STATUS:</b> APPROVED: <input type="checkbox"/> APPROVED AS NOTED: <input type="checkbox"/> REVISE AND RESUBMIT: <input type="checkbox"/> REJECTED: <input type="checkbox"/> NOTED: <input type="checkbox"/> FOR INFORMATION: <input type="checkbox"/>	

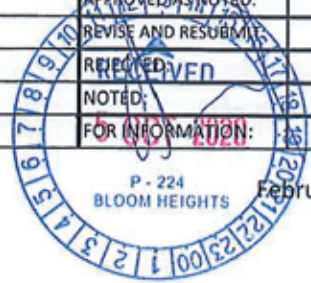



## Material Approval Request

Project: G+M+R Commercial Center on Plot No. 6150381 at Nad Al Shiba 2, Dubai-UAE.

Subject: DCD and Parking Signage Samples Ref: No. MS-117

Date: 13/08/2020

Rev. 01

We hereby submit the following material for your Approval / Comments:

Attachments:

Discipline:-

<input checked="" type="checkbox"/> Sample	<input type="checkbox"/> Civil	<input checked="" type="checkbox"/> Architectural
<input type="checkbox"/> Brochure catalog	<input type="checkbox"/> HVAC	<input type="checkbox"/> Electrical / L. Current
<input type="checkbox"/> Compliance Statement	<input type="checkbox"/> Plumbing / Drainage	<input type="checkbox"/> Fire Fighting / Alarm
<input type="checkbox"/> Others: Data Sheets	<input type="checkbox"/> Others (specify) :	<input type="checkbox"/>

Items Specified As per DCD requirements

Item Proposed Acrylic DCD internal signage and Parking Signage

Location of Use Corridors, service rooms, lifts and Parking

Specification Ref.

Drawing Ref.



Manufacturer Tech Craft

Country of Origin UAE

Local Agent Tech Craft

Other Information

CONSULTANT'S COMMENTS  Approved  Approved as Noted  Resubmit  Rejected

CONSULTANT		CONTRACTOR	
Received By:	Signature & Date:  13.08.2020	Submitted By: PM	Signature & Date:  13/8/20
Arch./Civil / MEP:	Signature & Date:	Received By:	Signature & Date:
Site Engineer:	Signature & Date:		
PM:	Signature & Date:		



Global Affairs  
Canada



Canada Pavilion at Expo 2020 Plot C, 38

**SAMPLE APPROVAL REQUEST FORM**

To	M/s. Ellisdon Middle East		
Attention	Mr. Ayman Hassan Elhalabi	Manuf./ Supplier:	M/S Tech Craft
Sample Tag No.	CAN-AMA-SAR-CV-IFA-033 Rev. A	Country of Origin:	UAE
Related Mat. Sub. No.	-	Sample/ Finish:	
Date	November 2, 2020	Catalogue Ref:	

SAMPLE APPROVAL REQUESTED FOR ITEMS

Sample approval for Signage

LOCATION WHERE USED

	Reviewed By	Approved By
Signature		
Name	Abdul Rahman	Tofic Al Turk
Designation	Project Coordinator	Sr. Project manager

CLIENT / CONSULTANT COMMENTS:

Code A: Approved    
  Code B: Approved with Comments    
  Code C: Rejected (Revise & Resubmit)    
  Code D: For Information

Client / Consultant Comments:

- \* Wood peaces per Sign should be consistent with same grain combination.
- \* Sign Edges to be dressed with paper lipping or trim edge to cover the fixation and grooves.
- \* Avoid bleeding at ink @
- \* Laser cut and Final finish as highlighted on the attached sheet
- \* Acrylic samples are acceptable. Fixation details to be provided
- \* Case labels & dimensions subject to approved shop drawings
- \* Above all subject to approved markup.

Signature:	Name: Ayman Al-Halabi	Date: 04.11.2020
------------	-----------------------	------------------

**PROJECT TITLE:** W1104 - G+ 3P+18+R Building on plot NO. 334-7114 at AlSatwa, Dubai **MATERIAL SUBMITTAL**

AH - Investments **MAKS**  **G & B Contracting LLC**

Ref. No: GB/MAKS/MA/166 Rev: 1 Date: 07-May-20 DISC: CIVIL

Submittal Title : SAMPLE SUBMITTAL FOR SIGNAGE BOARD

Item No.	Material Description	Location
1	<u>SAMPLE SUBMITTAL FOR SIGNAGE BOARD</u>	<u>INTERNAL &amp; EXTERNAL</u>

Manufacturer	M/s Tech Craft Advertising & Signs LLC
Country of Origin	UAE
Applicable Standards	N/A
Project spec. Ref.	N/A
BOQ Ref.	Bill no. 11/07
Location of use	Internal & External
Technical Details submitted as	: <input type="checkbox"/> Attachment <input type="checkbox"/> Catalogue
Sample Provided	: <input checked="" type="checkbox"/> Yes <input type="checkbox"/> No
Availability of Material	: <input checked="" type="checkbox"/> Local <input type="checkbox"/> Import
Lead Time Required	: <input checked="" type="checkbox"/> Yes <input type="checkbox"/> No
Time of Delivery to Site	30 days

Supplier Details: **MIS TECH CRAFT ADVERTISING & SIGNS LLC**  
 Company Name & Address: P.O Box - 487131, Dubai - UAE  
 Tel. No.: +971-43218432 Fax. No.: +971-42880945 Email: info@techcraftdubai.com

Compliance with Project Specifications :  Yes  Alternative (please fill below)  
**ALTERNATIVE MATERIAL**  
 Time Implication of Alternatives :  No  Yes  
 Cost Implication of Alternatives :  No  Yes  
 Reasons for Alternative (include supporting documents, if any)

The above mentioned material is submitted for your review / approval.  
 Submitted by: **M/s G&B Contracting LLC** Contractor's Representative: **Sijoy Johny (Proj. Manager)** Date: **07-May-20**

**CONSULTANT'S COMMENTS:**  
*No objection as per the attached sample board pic.*

**G & B CONTRACTING LLC**  
 Project : South Heights - Al Badaa  
**RECEIVED**  
 11 MAY 2020  
 BY: *[Signature]* 14:00

The aforementioned material has been -  
 A - Approved as submitted  
 B - Approved as noted Incorporate & proceed  
 C - Revise & Re-submit before work proceeds  
 D - Rejected

Received by Contractor: \_\_\_\_\_ Contractor's Representative: \_\_\_\_\_ Signature: \_\_\_\_\_ Date: \_\_\_\_\_

Distribution:  Employer  Consultant  Contractor  Others

<b>PROJECT TITLE:</b> W1104 - G+ 3P+18+R Building on plot No. 334-7114 at AlSatwa, Dubai		<b>MATERIAL SUBMITTAL SAMPLE</b>	
AH - Investments	<b>MAKS</b>		G & B Contracting LLC

Ref. No.: GB/MAKS/MA/166      Rev: 1      Date: 07-May-20      DISC: CIVIL

Submittal Title : **SAMPLE SUBMITTAL FOR SIGNAGE BOARD**

Item No.	Material Description	Location
1	<b>SAMPLE SUBMITTAL FOR SIGNAGE BOARD</b>	<b>INTERNAL &amp; EXTERNAL</b>

Manufacturer	M/s Tech Craft Advertising & Signs LLC
Country of Origin	UAE
Applicable Standards	N/A
Project specs. Ref.	N/A
BOQ Ref.	Bill no. 11/07
Location of use	Internal & External

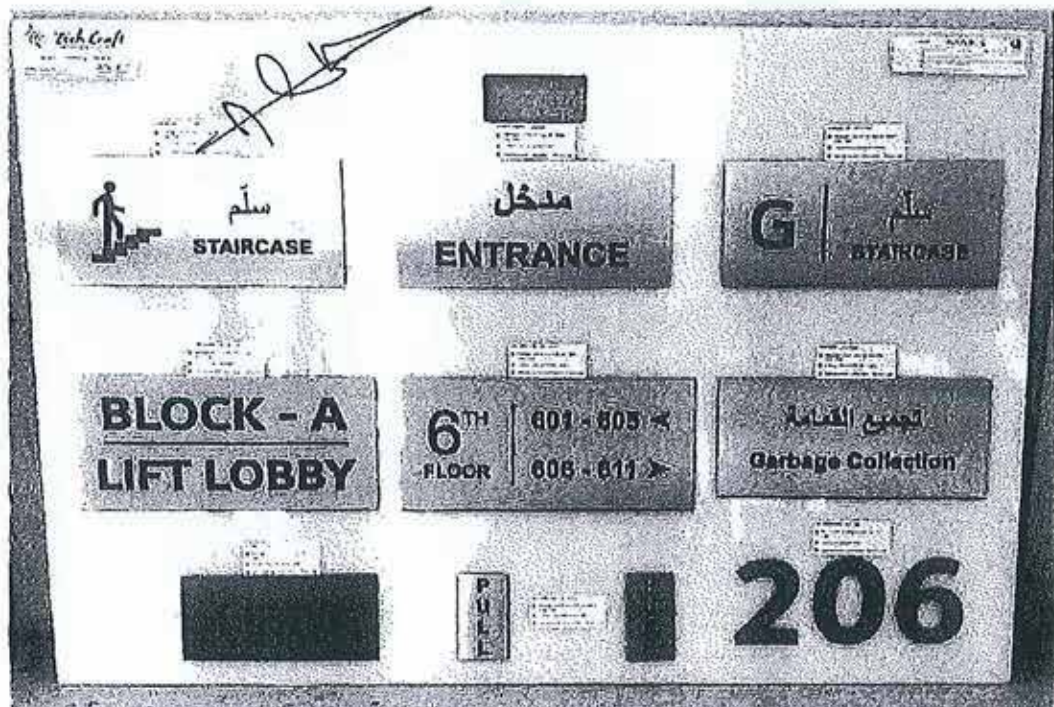

[ METHOD STATEMENT SUBMITTAL FORM ]

<b>Project: Al Zahia Uptown at Muwailih - Sharjah, UAE</b>			
Submittal Title:	<b>Method Statement</b>	Date	<b>25/05/2022</b>
Submittal No.:	<b>UNEC/J300/AR/MTS/064</b>	Revision	<b>0</b>

We are sending herewith under separate cover (please check one box):

<input checked="" type="checkbox"/> Architectural	<input type="checkbox"/> Structural	<input type="checkbox"/> Mechanical	<input type="checkbox"/> Electrical	<input type="checkbox"/> Plumbing
<input type="checkbox"/> Interior	<input type="checkbox"/> Landscape	<input type="checkbox"/> Other (specify)		

Ref. No.	Description	Description	Copies	Remarks
Drawing		<b>Installation of Internal Signage</b>	<b>Soft Copy</b>	
Specs.				
B.O.Q.				

Location of use: Designated plot for construction

<input type="checkbox"/> Manufacturer's Data	<input type="checkbox"/> Sample	<input type="checkbox"/> Guarantee	<input type="checkbox"/> Licenses & Certificates	<input type="checkbox"/> Test Certificate
<input type="checkbox"/> Catalogue	<input checked="" type="checkbox"/> Other			

Subcontractor/Supplier/Manufacturer:	<b>M/s. Tech Craft</b>		
Contractor Name:	Signature:	Date:	Received By:
<b>Ammar Al Saqer</b>		<b>25/05/2022</b>	
We certify that the documents/materials submitted herewith have been reviewed in detail and are in strict conformance with the contract drawings and specifications except as otherwise stated.			
Signature / Date:			

Lead Consultant Remarks				
<p>* Subjected to the performance on site</p> <p>* installation to be followed the approved Shop drawing &amp; Mockup.</p> <p>* Mock up to be provided on site.</p> <p>* Refer to the HSE Comments on the last page.</p>				
Approved	Approved as noted	Revise & Resubmit	Not Approved	Received By:
<input type="checkbox"/>	<input checked="" type="checkbox"/>	<input type="checkbox"/>	<input type="checkbox"/>	
RE - Sameh Habib 03/06/2022				Signature / Date:
Lead Consultant Name / Signature / Date				

Corrections or comments made relative to submittals during this review do not relieve the contractor from compliance with the requirements of The Contract. This check is only for review of general conformance with the design concept of the project and general compliance with the information given in the contract documents. The contractor is responsible for confirming and correlating all quantities and dimensions, selecting fabrication processes and techniques of construction, coordinating his work with that of other trades and performing his work in a safe and satisfactory manner.

Distribution:	<input type="checkbox"/> Consultant	<input type="checkbox"/> QS	<input type="checkbox"/> Contractor	<input type="checkbox"/> Others
---------------	-------------------------------------	-----------------------------	-------------------------------------	---------------------------------





Proposed Factory and G+M Office on Plot No. 5310643 & 5310644 at Dubai Industrial City

**SAMPLE APPROVAL REQUEST FORM**

To	Winner Holistic Consultant		
Attention	Mr. F.M. Mohideen, Head of the Project	Manuf./ Supplier:	Tech Craft
Sample Tag No.	DJ-291-P-CIV-STG-0043-01	Country of Origin:	UAE
Related Mat. Sub. No.	N/A	Sample/ Finish:	
Date	March 22, 2022	Catalogue Ref:	

**SAMPLE APPROVAL REQUESTED FOR ITEMS**

Sample for Internal & External Signages

**LOCATION WHERE USED**

Name Plate for Rooms & Services Plot 5 & 6

	Prepared By	Reviewed By	Approved By
Signature			
Name	Abdul Kabir E.	Rawan Afraz Alhalaseh	Ehab Ghattas
Designation	Site Document Controller	Projects Coordinator - Civil	Projects Manager

**CLIENT / CONSULTANT COMMENTS:**

- Code A: Approved     
  Code B: Approved with Comments     
  Code C: Rejected (Revise & Resubmit)     
  Code D: For Information

Client / Consultant Comments:

Approved.

+ screw holes not need, join the Signages / Roomnames with 3m strickets as agreed earlier.

Signature: Name: Rinshad Shaji Date: 22/03/2022



**PROJECT: SLB ACE BASE EXPANSION IN ICAD II, PLOT 147HR11**

**DRAWING TRANSMITTAL**

<b>To :</b>	M/s. Aurecon Australia Pty Ltd.	<b>TRANSMITTAL</b>	<b>DATE</b>
<b>Attention :</b>	Mr. Mohamed Elbadawi	<b>Amana:</b>	AJ-420-P-AUR-EN-DWG-0424
<b>Cc :</b>	M/s. Amana Contracting & Steel Buildings Co. W.L.L.		21-Jan-22

TYPE OF DRAWINGS		Reference List	
<input type="checkbox"/> Design Drawing	<input type="checkbox"/> Coordination Drawing	Specification :	N/A
<input checked="" type="checkbox"/> Shop Drawing	<input type="checkbox"/> Sketch Drawings	BOQ Reference :	N/A
<input type="checkbox"/> Calculation	<input type="checkbox"/> Others (Mobilization Drawings)	Drawing Ref: :	N/A

ATTACHMENTS OF DRAWING			
<input checked="" type="checkbox"/> Architectural Drawing	<input type="checkbox"/> Structural Drawing	<input type="checkbox"/> Steel Structural Drawing	<input type="checkbox"/> Structural Concrete Drawing
<input type="checkbox"/> Aluminum Drawings	<input type="checkbox"/> Builders Work Drawing	<input type="checkbox"/> Erection Drawings	<input type="checkbox"/> Others (Layout)

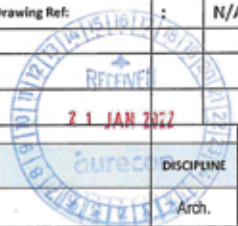

SN	DOCUMENT/DRAWING NO.	REV	DESCRIPTION	DISCIPLINE	ISSUED FOR
1	AJ-420-P-EN-SAR-01-TCA-0005	01	Building 01 – Layout, Ground Floor	Arch.	Approval
2	AJ-420-P-EN-SAR-01-TCA-0006	01	Building 01 – Ground Floor, Entrance Door	Arch.	Approval
3	AJ-420-P-EN-SAR-01-TCA-0007	01	Building 01 – Ground Floor, Reception Sign	Arch.	Approval
4	AJ-420-P-EN-SAR-01-TCA-0008	01	Building 01 – Ground Floor Signage and Fixation Details-A	Arch.	Approval
5	AJ-420-P-EN-SAR-01-TCA-0009	01	Building 01 – Ground Floor Signage and Fixation Details-B	Arch.	Approval
6	AJ-420-P-EN-SAR-01-TCA-0010	01	Building 01 – Ground Floor Signage and Fixation Details-C	Arch.	Approval
7	AJ-420-P-EN-SAR-01-TCA-0011	01	Building 01 – Ground Floor Signage and Fixation Details-E	Arch.	Approval
8	AJ-420-P-EN-SAR-01-TCA-0012	01	Building 01 – Ground Floor Signage and Fixation Details-D	Arch.	Approval
9	AJ-420-P-EN-SAR-01-TCA-0013	01	Building 01 – Ground Floor Signage and Fixation Details-F	Arch.	Approval
10	AJ-420-P-EN-SAR-01-TCA-0014	01	Building 01 – Signages Location Plan, Level 1	Arch.	Approval
11	AJ-420-P-EN-SAR-01-TCA-0015	01	Building 01 – Level 1 Floor Signage and Fixation Details-A	Arch.	Approval
12	AJ-420-P-EN-SAR-01-TCA-0016	01	Building 01 – Level 1 Floor Signage and Fixation Details-B	Arch.	Approval
13	AJ-420-P-EN-SAR-01-TCA-0017	01	Building 01 – Level 1 Floor Signage and Fixation Details-C	Arch.	Approval
14	AJ-420-P-EN-SAR-01-TCA-0018	01	Building 01 – Level 1 Floor Signage and Fixation Details-E	Arch.	Approval
15	AJ-420-P-EN-SAR-01-TCA-0019	01	Building 01 – Level 1 Floor Signage and Fixation Details-D	Arch.	Approval
16	AJ-420-P-EN-SAR-01-TCA-0020	01	Building 01 – Level 1 Floor Signage and Fixation Details-A	Arch.	Approval
17	AJ-420-P-EN-SAR-01-TCA-0021	01	Building 01 – Signages, Location Plan – Roof Plan	Arch.	Approval
18	AJ-420-P-EN-SAR-01-TCA-0022	01	Building 01 – Signages, Roof Floor Sign (a)	Arch.	Approval
19	AJ-420-P-EN-SAR-01-TCA-0023	01	Building 01 – Roof Floor Signage and Fixation Details-B	Arch.	Approval
20	AJ-420-P-EN-SAR-01-TCA-0024	01	Building 01 – Roof Floor Signage and Fixation Details-D	Arch.	Approval
21	AJ-420-P-EN-SAR-01-TCA-0025	00	Building 01 – Roof Floor Signage and Fixation Details-E	Arch.	Approval

Form# ADM-IMS-FRM-13-008 Rev.00

M. Project Manager - Agman Ruffa		Signature:	Date: 31/01/2022
<b>COMMENTS/REVISIONS COMMENTS:</b>			
No Objection - Please proceed for manufacture and installation by following few comments in the attached drawings. Consider all applicable approved project documents and authority standards. Cost saving applicable for all canceled signs. Submit schedule with original vs new scope of work.		<b>Approval Status (By Client):</b> <input type="checkbox"/> E-1: Approved <input checked="" type="checkbox"/> E-2: Approved with Comments <input type="checkbox"/> E-3: Not Approved (Please Re-submit) <input type="checkbox"/> E-4: For Information <input type="checkbox"/> E-5: Approval (No permit to work & required)	
For Consultant: Mr. Mohamed Elbadawi (Resident Engineer)		Signature:	Date: 31/01/2022
<b>CLIENT/OWNER COMMENTS:</b>			
		<b>Approval Status (By Client):</b> <input type="checkbox"/> E-1: Approved <input type="checkbox"/> E-2: Approved with Comments <input type="checkbox"/> E-3: Not Approved (Please Re-submit) <input type="checkbox"/> E-4: For Information <input type="checkbox"/> E-5: Approval (No permit to work & required)	
For Client:	Signature:	Date:	
Amana Receiver's:	Signature & Stamp:	Date:	





**JOTUN R&D Laboratory & Regional Office  
Main Works Contract**

Arcadis ref. 10037346  
Dubai Science Park, UAE



**Shop Drawing Submittal**

Issued by: *Amana Contracting & Steel Buildings LLC*  
 Issued to: *Arcadis Consulting Middle East Ltd.*  
 CC: *Jotun MEIA FZ-LLC*

SDS Ref. No.	Orig. JRD-AMN	Doc Type SD-ARC	Serial No. 0039	Rev. 02	Date: 19-Aug-21
--------------	---------------	-----------------	-----------------	---------	-----------------

Discipline :  Arch.  Struct.  Mech.  Elect  VT  Facade  Others.....

AMANA certifies that the following documents/drawings have been checked, coordinated and found to be in compliance with project specifications

Submittal Code	
Approval	1
Information	2

Item	Qty.	Document / Drawing No.	Item Description	Sub. Code
1	1	DJ-277-P-EN-SAR-00-TEC-0001-02	Traffic Sign Underground 1 Layout	
2	1	DJ-277-P-EN-SAR-00-TEC-0002-02	Traffic Sign Level 0 Layout	1
3	1	DJ-277-P-EN-SAR-00-TEC-0003-01	Traffic Sign Artwork Design # 01	1
4	1	DJ-277-P-EN-SAR-00-TEC-0004-02	Traffic Sign Detailed Drawing # 01	1
5	1	DJ-277-P-EN-SAR-00-TEC-0005-00	Traffic Sign Drawing # 02	1
6	1	DJ-277-P-EN-SAR-00-TEC-0006-00	Traffic Sign Detailed Drawing # 02	1

<p><b>For Contractor</b></p> <p>Prepared / Reviewed by: <i>Jameel Ahmad Khan</i> Signature <i>JAK</i> Date: 19-Aug-21</p> <p>Prepared / Checked by: <i>Fadi Al Agha</i> Signature <i>FAD</i> Date: 19-Aug-21</p> <p>Approved by: <i>Joseph Yazbek</i> Signature _____ Date: 19-Aug-21</p>	<p><b>Receipt Acknowledged by :</b></p> <p>Received By : <b>ARCADIS</b></p> <p>Date : <b>22 August 2021</b></p> <p>Time : .....</p>
---	---

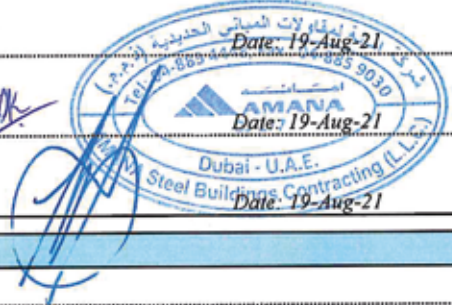

**Consultant Review & Comments :**

1. Refer to comments on the drawings.
2. Any changes from previous submission are to be clouded to highlight. In absence of the same the consultant bear no responsibility for any missed out review comments and unnoticed information on the drawings.
3. These drawings are to be resubmitted for further review and approval, prior to start of work on site.

*This response does not alter the Contract or diminish the Contractor's responsibility to complete the Works in full accordance with the Contract and does not comprise a variation to the Contract. Should the Contractor require a change in the Contract cost or time, he shall submit an itemized proposal and obtain the Employer's agreement prior to proceeding with Works*

**Returned to Contractor with Status :**

A : Approved  B: Approved as noted  C: Revise / Resubmit  D: Information

<p><b>For Consultant</b></p> <p>Signature .....</p> <p>Date : ..... 26 August 2021</p>	<p><b>Receipt Acknowledged by AMANA</b></p> <p>Received by : .....</p>
--	--

Distribution :  Employer  Employer's Representative  Quantity surveyor  others (.....)



**[ SHOP DRAWING SUBMITTAL FORM ]**

PROJECT TITLE:	<b>The Construction, Completion and Maintenance of (Al Zahia Uptown) Comprising of Phase A &amp; B on Plot Number 483/1868-6347 at Muwailih, Sharjah – UAE</b>		
CONTRACT ADM.: M/s. Currie & Brown ENGINEER: M/s. Engineering Consultants Group	EMPLOYER : M/s. Majid Al Futtaim Properties		
Submittal Ref. No: <b>UNEC-J300-GM-SD-LS-SG-005</b>	Date: <b>22 Mar 2022</b>	Rev: <b>00</b>	
Previous Submittal Ref. No: <b>NIL</b>	Dated : <b>NIL</b>		
Originator : <b>Green &amp; More Landscape LLC</b>	Sign of Originator:		

- Discipline:  STR  ARCH  ID  EL  MECH  PL  HVAC  FF  INFRA  LS  
 BREEAM  HSE  OTHERS.....

We are sending herewith under separate cover the drawings listed below:

SUBMITTAL TITLE		Pedestrian Directional Sign (Uptown)			
S.N.	DRAWING No.	REV.	DESCRIPTION	Copies	Engineer's Action
1	GM-J300-SD-A+B-OA-GR-LS-SG-3-762	00	Pedestrian Directional Sign	2	
2	GM-J300-SD-A+B-OA-GR-LS-SG-3-763	00	Pedestrian Directional Sign Design	2	

	<b>MAIN CONTRACTOR</b>	<b>RECEIVED BY LEAD CONSULTANT</b>
	Signature: .....	Signature: ..... Date: .....

FOR THE LEAD CONSULTANT			
Status A	Status B	Status C	Status D
Approved	Approved As noted	Revise & Resubmit	Rejected

Refer to the notes/comments on the drawing sheets

	Lea Mendoza - Arch. Engr. - FIONA
SIGNATURE AND DATE OF DECISION BY THE LEAD CONSULTANT.	RE - Sameh Habib 13/04/2022
SUB-CONTRACTOR RECEIVED SIGNATURE:	

SIGNATURE AND DATE OF RECEIPT BY CONTRACTOR'S REPRESENTATIVE.



**[ SHOP DRAWING SUBMITTAL FORM ]**

PROJECT TITLE:	<b>The Construction, Completion and Maintenance of (Al Zahia Uptown) Comprising of Phase A &amp; B on Plot Number 483/1868-6347 at Muwailih, Sharjah - UAE</b>		
CONTRACT ADM.: M/s. Currie & Brown ENGINEER: M/s. Engineering Consultants Group	EMPLOYER : M/s. Majid Al Futtaim Properties		
<b>Submittal Ref. No: UNEC-J300-GM-SD-LS-SG-006</b>	<b>Date: 22 Mar 2022</b>	<b>Rev: 00</b>	
Previous Submittal Ref. No: <b>NIL</b>	Dated : <b>NIL</b>		
Originator : <b>Green &amp; More Landscape LLC</b>	Sign of Originator: 		



- Discipline:  STR  ARCH  ID  EL  MECH  PL  HVAC  FF  INFRA  LS  
 BREEAM  HSE  OTHERS.....

We are sending herewith under separate cover the drawings listed below:

SUBMITTAL TITLE		Pedestrian Entrance Sign (Uptown)			
S.N.	DRAWING No.	REV.	DESCRIPTION	Copies	Engineer's Action
1	GM-J300-SD-A+B-OA-GR-LS-SG-3-764	00	Pedestrian Entrance Sign	2	
2	GM-J300-SD-A+B-OA-GR-LS-SG-3-765	00	Pedestrian Entrance Sign	2	

  
**MAIN CONTRACTOR**  
 Signature: .....

**RECEIVED BY LEAD CONSULTANT**  
 Signature: ..... Date: .....

FOR THE LEAD CONSULTANT			
Status A	Status B	Status C	Status D
Approved	Approved As noted	Revise & Resubmit	Rejected

**Refer to the notes on the drawing sheet**

 **Lea Mendosa - Arch Engr. - M/s PTONA**

SIGNATURE AND DATE OF DECISION BY THE LEAD CONSULTANT.  
**RE - Sameh Habib**  
**13/04/2022**

SIGNATURE AND DATE OF RECEIPT BY CONTRACTOR'S REPRESENTATIVE.

SUB-CONTRACTOR RECEIVED SIGNATURE:



**[ SHOP DRAWING SUBMITTAL FORM ]**

PROJECT TITLE:	<b>The Construction, Completion and Maintenance of (Al Zahia Uptown) Comprising of Phase A &amp; B on Plot Number 483/1868-6347 at Muwailih, Sharjah - UAE</b>		
CONTRACT ADM.: M/s. Currie & Brown ENGINEER: M/s. Engineering Consultants Group	EMPLOYER : M/s. Majid Al Futtaim Properties		
Submittal Ref. No: <b>UNEC-J300-GM-SD-LS-SG-007</b>	Date: <b>22 Mar 2022</b>	Rev:	
Previous Submittal Ref. No: <b>NIL</b>	Dated : <b>NIL</b>		
Originator : <b>Green &amp; More Landscape LLC</b>	Sign of Originator:		

- Discipline:  STR  ARCH  ID  EL  MECH  PL  HVAC  FF  INFRA  LS  
 BREEAM  HSE  OTHERS.....

We are sending herewith under separate cover the drawings listed below:

SUBMITTAL TITLE		Car Park Sign (Uptown)			
S.N.	DRAWING No.	REV.	DESCRIPTION	Copies	Engineer's Action
1	GM-J300-SD-A+B-OA-GR-LS-SG-3-766	00	Car Park Sign	2	
2	GM-J300-SD-A+B-OA-GR-LS-SG-3-767	00	Car Park Sign Design	2	

<b>MAIN CONTRACTOR</b> Signature:	<b>RECEIVED BY LEAD CONSULTANT</b> Signature: ..... Date: .....
--------------------------------------	--

**FOR THE LEAD CONSULTANT**

<b>Status A</b>	<b>Status B</b>	<b>Status C</b>	<b>Status D</b>
Approved	Approved As noted	Revise & Resubmit	Rejected

**Refer to comments on the drawing sheets**

SIGNATURE AND DATE OF DECISION BY THE LEAD CONSULTANT. RE - Sameh Habib 13/04/2022 	SIGNATURE AND DATE OF RECEIPT BY CONTRACTOR'S REPRESENTATIVE. M/s Lea Mendoza - Arch Engr. - FIDNA 
SUB-CONTRACTOR RECEIVED SIGNATURE:	



**[ SHOP DRAWING SUBMITTAL FORM ]**

<b>PROJECT TITLE:</b>	<b>The Construction, Completion and Maintenance of (Al Zahia Uptown) Comprising of Phase A &amp; B on Plot Number 483/1868-6347 at Muwaillih, Sharjah – UAE</b>		
<b>CONTRACT ADM.:</b> M/s. Currie & Brown	<b>ENGINEER:</b> M/s. Engineering Consultants Group		<b>EMPLOYER :</b> M/s. Majid Al Futtaim Properties
<b>Submittal Ref. No:</b> UNEC-J300-GM-SD-LS-SG-008	<b>Date:</b> 22 Mar 2022	<b>Rev:</b> 00	
<b>Previous Submittal Ref. No:</b> NIL		<b>Dated :</b> NIL	
<b>Originator :</b> Green & More Landscape LLC	<b>Sign of Originator:</b>		



- Discipline:  STR  ARCH  ID  EL  MECH  PL  HVAC  FF  INFRA  LS
- BREEAM  HSE  OTHERS... ..

We are sending herewith under separate cover the drawings listed below:

SUBMITTAL TITLE		Building Entrance Sign (Uptown)			
S.N.	DRAWING No.	REV.	DESCRIPTION	Copies	Engineer's Action
1	GM-J300-SD-A+B-OA-GR-LS-SG-3-768	00	Building Entrance Sign	2	

<b>MAIN CONTRACTOR</b>	<b>RECEIVED BY LEAD CONSULTANT</b>
Signature:	Signature: ..... Date: .....

FOR THE LEAD CONSULTANT			
Status A	Status B	Status C	Status D
Approved	Approved As noted	Revise & Resubmit	Rejected

**Refer to notes on the drawing sheet**

---



---



---

<b>SIGNATURE AND DATE OF DECISION BY THE LEAD CONSULTANT.</b> RE - Sameh Habib 13/04/2022	<b>SIGNATURE AND DATE OF RECEIPT BY CONTRACTOR'S REPRESENTATIVE.</b>
<b>SUB-CONTRACTOR RECEIVED SIGNATURE:</b>	

# AMANA

November 25, 2021

Ref: AJ-420-P-TCA-OP-LTR-0007

Encl. : 1+ Encl.

P.O. Box 5643  
Abu Dhabi, UAE  
Tel: +971 2 6428383  
Fax: +971 2 6428644

**M/s. Tech Craft Metal Industries L.L.C**

P.O. Box. 487131

Dubai, UAE

Phone : 04-288 0945

ص.ب. ٥٦٤٣  
أبوظبي، ا.ع.م.  
هاتف: +٩٧١ ٢ ٦٤٢٨٣٨٣  
فاكس: +٩٧١ ٢ ٦٤٢٨٦٤٤

**Attention : Mr. Maher / Ms. Abeer**

**Project : SLB ACE Base Expansion in ICAD II, Plot 97BR10**

**Subject : Approved Shop Drawings for Staircase Handrail**

Dear Maher / Abeer,

With reference to the abovementioned project, please find attached the following shop drawings duly reviewed and approved (with comments) by the Consultant:

Transmittal No.	Description	Status
AJ-420-P-AUR-EN-DWG-0334-00	Shop Drawings for Staircase Handrail	B

You are kindly requested to proceed with fabrication accordingly, with considering the Consultant's comments.

Best Regards,

**For Amana Contracting and Steel Buildings Co. W.L.L**

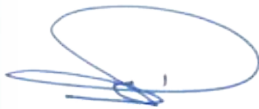

**Ayman Naffa**

**Sr. Project Manager**

M: +971 50 6670982

E: [ayman.naffa@amanabuildings.com](mailto:ayman.naffa@amanabuildings.com)

W: [www.amanabuildings.com](http://www.amanabuildings.com)



ABU DHABI







**PROJECT: SLB ACE BASE EXPANSION IN ICAD II, PLOT 147HR11**  
**DRAWING TRANSMITTAL**

To :	M/s. Aurecon Australia Pty Ltd.	TRANSMITTAL	DATE
Attention :	Mr. Mohamed Elbadawi	Amana:	30-Oct-21
Cc :	M/s. Amana Contracting and Steel Building Co. W.L.L.	AJ-420-P-AUR-EN-DWG-0334	

**TYPE OF DRAWINGS**

<input type="checkbox"/> As Built Drawings	<input type="checkbox"/> Coordination Drawing	Specification	:	N/A
<input checked="" type="checkbox"/> Shop Drawing	<input type="checkbox"/> Sketch Drawings	BOQ Reference	:	N/A
<input type="checkbox"/> Calculation	<input type="checkbox"/> Others (Mobilization Drawings)	Drawing Ref.	:	N/A

**ATTACHMENTS OF DRAWING**

<input checked="" type="checkbox"/> Architectural Drawing	<input type="checkbox"/> Structural Drawing	<input type="checkbox"/> Steel Structural Drawing	<input type="checkbox"/> Structural Concrete Drawing	<input type="checkbox"/> Others (layout)
<input type="checkbox"/> Aluminum Drawings	<input type="checkbox"/> Builders Work Drawing	<input type="checkbox"/> Erection Drawings	<input type="checkbox"/> Others (layout)	

SN	DOCUMENT/DRAWING NO.	REV	DESCRIPTION	DISCIPLINE	ISSUED FOR
1	AJ-420-P-EN-SAR-01-TCA-0003	00	Staircase Handrail Details	Arch.	Approval
2	AJ-420-P-EN-SAR-01-TCA-0004	00	Staircase Handrail Details	Arch.	Approval

Sr. Project Manager – Ayman Naffa

Signature:

Date: 30-Oct-2021

CONSULTANT/ENGINEER COMMENTS:

No Objection proceed in coordination and comments previously given on AJ-420-P-AUR-EN-DWG-0316. Subject to compliance with project specifications and applicable authority standards.

Approval Status (By Consultant)

- Code A: Approved
- Code B: Approved with Comments
- Code C: Not Approved (Revise & Resubmit)
- Code D: For Information
- Code E: Rejection (No permit to revise & resubmit)

For Consultant : Mr. Mohamed Elbadawi (Resident Engineer)

Signature:

Date: 23/11/2021

CLIENT/EMPLOYER COMMENTS:

Approval Status (By Client)

- Code A: Approved
- Code B: Approved with Comments
- Code C: Not Approved (Revise & Resubmit)
- Code D: For Information
- Code E: Rejection (No permit to revise & resubmit)

For Client:

Signature:

Date:

Amana Receiver's:

Signature & Stamp:

Date:





# SITE INSPECTION REQUEST (SIR)



<b>Project</b>	A100 - IRIS DATA CENTER - EXTERNAL PACKAGE	<b>SIR No.</b>	MMC-IRIE-IRIG-CV-SIR-0747-01	
<b>Client / Consultant</b>	PIVOT / SUDLOWS	<b>Initiation Date</b>	15/06/2022	
<b>Design Consultant</b>	CLOSE SYSTEM	<b>Required Date</b>	17/06/2022	<b>Time:</b> 09:00 AM

**Subject** Inspection for installation of Signages in Utility Building-IRIS

<b>CIVIL</b>	<b>STRU</b>	<b>ARCH</b>	<b>ELEC</b>	<b>MECH</b>	<b>PL</b>	<b>ELV</b>	<b>FP</b>	<b>ICT</b>	<b>Other</b>
--------------	-------------	-------------	-------------	-------------	-----------	------------	-----------	------------	--------------

**REFERENCES:**

<b>SDS / Drawing No.</b>	MMC-IRIE-IRIG-ST-SDS-7802-01
<b>Specification No.</b>	
<b>MTS Ref No.</b>	MMC-IRIE-IRIG-AR-MTS-0026-00
<b>MSS Ref No.</b>	LOCATION: IRIS - Utility Building

**Inspection Description**

Inspection for installation of Signages in Utility Building-IRIS as per attached highlighted drawing.

**Attachments:** Shop Drawings, Material Submittal, Method statement with reference as stated above

Requested by Contractor			Received by Design Consultant	
Name	Manikandan/ECC	Hafeez U./MMC	Name	Malik S. Ahmed
Date	15/06/2022	15/06/2022	Date	16/06/2022
Signature			Signature	

**Design Consultant Comments**

- Fixing of the signages to be using high-quality double side tape and as per the approved SDS.

Code A - Approved <input type="checkbox"/>	Code B - Approved w/ comments <input checked="" type="checkbox"/>	Code C - Revised & Resubmit <input type="checkbox"/>
--	---	--

Requested by Main Contractor		Received by Client Consultant	
Name		Name	
Date		Date	
Signature		Signature	

**Client Consultant Comments**

Code A - Approved <input type="checkbox"/>	Code B - Approved w/ comments <input type="checkbox"/>	Code C - Revised & Resubmit <input type="checkbox"/>
--	--	--

CC:

	<b>SITE INSPECTION REQUEST (SIR)</b>	
---	--	---

<b>Project</b>	A100 - IRIS DATA CENTER - EXTERNAL PACKAGE	<b>SIR No.</b>	MMC-IRIE-IRIG-CV-SIR-0747-00
<b>Client / Consultant</b>	PIVOT / SUDLOWS	<b>Initiation Date</b>	26/05/2022
<b>Design Consultant</b>	CLOSE SYSTEM	<b>Required Date</b>	27/05/2022 <b>Time:</b> 09:00 AM

<b>Subject</b>	Inspection for installation of Signages in Utility Building-IRIS								
<b>CIVIL</b>	<b>STRU</b>	<b>ARCH</b>	<b>ELEC</b>	<b>MECH</b>	<b>PL</b>	<b>ELV</b>	<b>FP</b>	<b>ICT</b>	<b>Other</b>



**REFERENCES:**

<b>SDS / Drawing No.</b>	MMC-IRIE-IRIG-ST-SDS-7802-01
<b>Specification No.</b>	
<b>MTS Ref No.</b>	HWI-IRI1-CV-MTS-0092-00
<b>MSS Ref No.</b>	LOCATION: IRIS - Utility Building

**Inspection Description**

Inspection for installation of Signages in Utility Building-IRIS as per attached highlighted drawing.

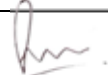
**Attachments:** Shop Drawings, Material Submittal, Method statement with reference as stated above

Requested by Contractor			Received by Design Consultant	
Name	Manikandan/ECC	Hafeez U./MMC	Name	Malik S. Ahmed
Date	26/05/2022	26/05/2022	Date	26-05-2022
Signature			Signature	

**Design Consultant Comments**

- Mentioned MTS ref no. is not related to the external package and has not been included in the undertaking letter, therefore, Material submittal is to be submitted for the reviewing.

<b>Code A - Approved</b> <input type="checkbox"/>	<b>Code B - Approved w/ comments</b> <input type="checkbox"/>	<b>Code C - Revised &amp; Resubmit</b> <input checked="" type="checkbox"/>
---	---	--

Requested by Main Contractor		Received by Client Consultant	
Name		Name	
Date		Date	
Signature		Signature	

**Client Consultant Comments**

<b>Code A - Approved</b> <input type="checkbox"/>	<b>Code B - Approved w/ comments</b> <input type="checkbox"/>	<b>Code C - Revised &amp; Resubmit</b> <input type="checkbox"/>
---	---	---

CC:

**CLOSE SYSTEMS SUBMITTAL RESPONSE SHEET**

Discipline: ARCHITECTURAL  
 Document Title: MATERIAL SUBMITTAL FOR EXTERNAL SIGNAGE  
 Document No.: MMC-IRIE-IRIG-AR-MTS-0026-00  
 Transmittal No.: 351-CSC-MMC-TRANS- 2323  
 Issued To : MENASCO MECHANICAL CONTRACTING LLC

Received Date: 14-June-2022

Sn	Comments	Status	Issued Date	Signature
1	All material must comply with Authorities regulations and requirements	B	14/06/2022	WE
2	Coordination and other necessary approval is the contractor responsibility	B	14/06/2022	WE
3	Final approval subject to client & physical sample approval	B	14/06/2022	WE
4				
5				

Status	A	-	Approved with No Comments.
Status	<b>B</b>	-	<b>Approved with Comments. Contractor may proceed ensuring comments are addressed and incorporated. No resubmission is required.</b>
Status	C	-	<b>Revise and resubmit. Contractor may not proceed. Contractor to resubmit incorporating comments.</b>
Status	D	-	Rejected. No further resubmission is required.

Reviewed by: Eng. Wagdi Mohamed El  
 Hassan El Samani  
 Sr. Architect

Signature:   
 Date: 14-06-2022





## SITE INSPECTION REQUEST (SIR)



<b>Project</b>	A100 - IRIS DATA CENTER - EXTERNAL PACKAGE	<b>SIR No.</b>	MMC-IRIE-IRIG-CV-SIR-0748-01	
<b>Client / Consultant</b>	PIVOT / SUDLOWS	<b>Initiation Date</b>	15/06/2022	
<b>Design Consultant</b>	CLOSE SYSTEM	<b>Required Date</b>	17/06/2022	<b>Time:</b> 09:00 AM

**Subject** Inspection for installation of Signages in MV Intake room-IRIS

<b>CIVIL</b>	<b>STRU</b>	<b>ARCH</b>	<b>ELEC</b>	<b>MECH</b>	<b>PL</b>	<b>ELV</b>	<b>FP</b>	<b>ICT</b>	<b>Other</b>
--------------	-------------	-------------	-------------	-------------	-----------	------------	-----------	------------	--------------

**REFERENCES:**

<b>SDS / Drawing No.</b>	MMC-IRIE-IRIG-ST-SDS-3901-03, MMC-IRIE-IRIG-ST-SDS-3902-02, MMC-IRIE-IRIG-ST-SDS-3905-02			
<b>Specification No.</b>				
<b>MTS Ref No.</b>	MMC-IRIE-IRIG-AR-MTS-0026-00			
<b>MSS Ref No.</b>	LOCATION: IRIS - MV Intake room			

**Inspection Description**

Inspection for installation of Signages in MV Intake room-IRIS as per attached highlighted drawing.

**Attachments:** Shop Drawings, Material Submittal, Method statement with reference as stated above

Requested by Contractor			Received by Design Consultant	
Name	Manikandan/ECC	Hafeez U./MMC	Name	Malik S. Ahmed
Date	15/06/2022	15/06/2022	Date	17/06/2022
Signature			Signature	

**Design Consultant Comments**

- Fixing of the signages to be using high-quality double side tape and as per the approved SDS.



<b>Code A - Approved</b> <input type="checkbox"/>	<b>Code B - Approved w/ comments</b> <input checked="" type="checkbox"/>	<b>Code C - Revised &amp; Resubmit</b> <input type="checkbox"/>
---	--	---

Requested by Main Contractor		Received by Client Consultant	
Name		Name	
Date		Date	
Signature		Signature	

**Client Consultant Comments**

<b>Code A - Approved</b> <input type="checkbox"/>	<b>Code B - Approved w/ comments</b> <input type="checkbox"/>	<b>Code C - Revised &amp; Resubmit</b> <input type="checkbox"/>
---	---	---

CC:

	<b>SITE INSPECTION REQUEST (SIR)</b>	
---	--	---

<b>Project</b>	A100 - IRIS DATA CENTER - EXTERNAL PACKAGE	<b>SIR No.</b>	MMC-IRIE-IRIG-CV-SIR-0748-00
<b>Client / Consultant</b>	PIVOT / SUDLOWS	<b>Initiation Date</b>	26/05/2022
<b>Design Consultant</b>	CLOSE SYSTEM	<b>Required Date</b>	27/05/2022 <b>Time:</b> 09:00 AM

<b>Subject</b>	Inspection for installation of Signages in MV Intake room-IRIS								
<b>CIVIL</b>	<b>STRU</b>	<b>ARCH</b>	<b>ELEC</b>	<b>MECH</b>	<b>PL</b>	<b>ELV</b>	<b>FP</b>	<b>ICT</b>	<b>Other</b>





**REFERENCES:**

<b>SDS / Drawing No.</b>	MMC-IRIE-IRIG-ST-SDS-3901-03, MMC-IRIE-IRIG-ST-SDS-3902-02, MMC-IRIE-IRIG-ST-SDS-3905-02
<b>Specification No.</b>	
<b>MTS Ref No.</b>	HWI-IRI1-CV-MTS-0092-00
<b>MSS Ref No.</b>	LOCATION: IRIS - Utility Building

**Inspection Description**

Inspection for installation of Signages in MV Intake room-IRIS as per attached highlighted drawing.

**Attachments:** Shop Drawings, Material Submittal, Method statement with reference as stated above

Requested by Contractor			Received by Design Consultant		
Name	Manikandan/ECC	Hafeez U./MMC	Name	 <small>Malik S. Ahmed ARCHITECTURAL CONSULTANT LLC</small>	
Date	26/05/2022	26/05/2022	Date	 <b>RECEIVED</b>	
Signature			Signature		

**Design Consultant Comments**

- Mentioned MTS ref no. is not related to the external package and has not been included in the undertaking letter, therefore, Material submittal is to be submitted for the reviewing.

<b>Code A - Approved</b> <input type="checkbox"/>	<b>Code B - Approved w/ comments</b> <input type="checkbox"/>	<b>Code C - Revised &amp; Resubmit</b> <input checked="" type="checkbox"/>
---	---	--

Requested by Main Contractor		Received by Client Consultant	
Name		Name	
Date		Date	
Signature		Signature	

**Client Consultant Comments**

<b>Code A - Approved</b> <input type="checkbox"/>	<b>Code B - Approved w/ comments</b> <input type="checkbox"/>	<b>Code C - Revised &amp; Resubmit</b> <input type="checkbox"/>
---	---	---

CC:

**CLOSE SYSTEMS SUBMITTAL RESPONSE SHEET**

Discipline: ARCHITECTURAL  
 Document Title: MATERIAL SUBMITTAL FOR EXTERNAL SIGNAGE  
 Document No.: MMC-IRIE-IRIG-AR-MTS-0026-00  
 Transmittal No.: 351-CSC-MMC-TRANS-  
 Issued To : MENASCO MECHANICAL CONTRACTING LLC



**Received Date: 14-June-2022**

Sn	Comments	Status	Issued Date	Signature
1	All material must comply with Authorities regulations and requirements	B	14/06/2022	WE
2	Coordination and other necessary approval is the contractor responsibility	B	14/06/2022	WE
3	Final approval subject to client & physical sample approval	B	14/06/2022	WE
4				
5				

Status	A	-	Approved with No Comments.
Status	<b>B</b>	-	<b>Approved with Comments. Contractor may proceed ensuring comments are addressed and incorporated. No resubmission is required.</b>
Status	C	-	<b>Revise and resubmit. Contractor may not proceed. Contractor to resubmit incorporating comments.</b>
Status	D	-	Rejected. No further resubmission is required.

Reviewed by: Eng. Wagdi Mohamed El Hassan El Samani Sr. Architect	Signature: 
	Date: 14-06-2022



	<b>SITE INSPECTION REQUEST (SIR)</b>	
---	--	---

<b>Project</b>	A100 - IRIS DATA CENTER - EXTERNAL PACKAGE	<b>SIR No.</b>	MMC-IRIE-IRIG-CV-SIR-0749-01
<b>Client / Consultant</b>	PIVOT / SUDLOWS	<b>Initiation Date</b>	15/06/2022
<b>Design Consultant</b>	CLOSE SYSTEM	<b>Required Date</b>	17/06/2022 <b>Time:</b> 09:00 AM

<b>Subject</b>	Inspection for installation of Signages in Guard House(Entrance & Internal)-IRIS								
<b>CIVIL</b>	<b>STRU</b>	<b>ARCH</b>	<b>ELEC</b>	<b>MECH</b>	<b>PL</b>	<b>ELV</b>	<b>FP</b>	<b>ICT</b>	<b>Other</b>



**REFERENCES:**

<b>SDS / Drawing No.</b>	MMC-IRIE-IRIG-ST-SDS-3901-03, MMC-IRIE-IRIG-ST-SDS-3902-02, MMC-IRIE-IRIG-ST-SDS-3905-02
<b>Specification No.</b>	
<b>MTS Ref No.</b>	MMC-IRIE-IRIG-AR-MTS-0026-00
<b>MSS Ref No.</b>	LOCATION: IRIS - Guard House(Entrance & Internal)

**Inspection Description**

Inspection for installation of Signages in Guard House(Entrance & Internal)-IRIS as per attached highlighted drawing.

**Attachments:** Shop Drawings, Material Submittal, Method statement with reference as stated above

Requested by Contractor			Received by Design Consultant	
Name	Manikandan/ECC	Hafeez U./MMC	Name	Malik S. Ahmed
Date	15/06/2022	15/06/2022	Date	17/06/2022
Signature			Signature	

**Design Consultant Comments**

- Fixing of the signages to be using high-quality double side tape and as per the approved SDS.



<b>Code A - Approved</b> <input type="checkbox"/>	<b>Code B - Approved w/ comments</b> <input checked="" type="checkbox"/>	<b>Code C - Revised &amp; Resubmit</b> <input type="checkbox"/>
---	--	---



Requested by Main Contractor		Received by Client Consultant	
Name		Name	
Date		Date	
Signature		Signature	

**Client Consultant Comments**

<b>Code A - Approved</b> <input type="checkbox"/>	<b>Code B - Approved w/ comments</b> <input type="checkbox"/>	<b>Code C - Revised &amp; Resubmit</b> <input type="checkbox"/>
---	---	---

CC:



	<b>SITE INSPECTION REQUEST (SIR)</b>	
---	--	---

<b>Project</b>	A100 - IRIS DATA CENTER - EXTERNAL PACKAGE	<b>SIR No.</b>	MMC-IRIE-IRIG-CV-SIR-0749-00
<b>Client / Consultant</b>	PIVOT / SUDLOWS	<b>Initiation Date</b>	26/05/2022
<b>Design Consultant</b>	CLOSE SYSTEM	<b>Required Date</b>	27/05/2022 <b>Time:</b> 09:00 AM

<b>Subject</b>	Inspection for installation of Signages in Guard House(Entrance & Internal)-IRIS								
<b>CIVIL</b>	<b>STRU</b>	<b>ARCH</b>	<b>ELEC</b>	<b>MECH</b>	<b>PL</b>	<b>ELV</b>	<b>FP</b>	<b>ICT</b>	<b>Other</b>



**REFERENCES:**

<b>SDS / Drawing No.</b>	MMC-IRIE-IRIG-ST-SDS-3901-03, MMC-IRIE-IRIG-ST-SDS-3902-02, MMC-IRIE-IRIG-ST-SDS-3905-02
<b>Specification No.</b>	
<b>MTS Ref No.</b>	HWI-IRI1-CV-MTS-0092-00
<b>MSS Ref No.</b>	LOCATION: IRIS - Utility Building

**Inspection Description**

Inspection for installation of Signages in Guard House(Entrance & Internal)-IRIS as per attached highlighted drawing.

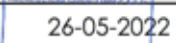
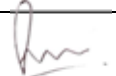
**Attachments:** Shop Drawings, Material Submittal, Method statement with reference as stated above

Requested by Contractor			Received by Design Consultant		
Name	Manikandan/ECC	Hafeez U./MMC	Name	 Malik S. Ahmed	
Date	26/05/2022	26/05/2022	Date	 26-05-2022	
Signature			Signature	 RECEIVED	

**Design Consultant Comments**

- Mentioned MTS ref no. is not related to the external package and has not been included in the undertaking letter, therefore, Material submittal is to be submitted for the reviewing.



<b>Code A - Approved</b> <input type="checkbox"/>	<b>Code B - Approved w/ comments</b> <input type="checkbox"/>	<b>Code C - Revised &amp; Resubmit</b> <input checked="" type="checkbox"/>
---	---	--

Requested by Main Contractor		Received by Client Consultant	
Name		Name	
Date		Date	
Signature		Signature	

**Client Consultant Comments**

<b>Code A - Approved</b> <input type="checkbox"/>	<b>Code B - Approved w/ comments</b> <input type="checkbox"/>	<b>Code C - Revised &amp; Resubmit</b> <input type="checkbox"/>
---	---	---

CC:

**CLOSE SYSTEMS SUBMITTAL RESPONSE SHEET**

**Discipline: ARCHITECTURAL**  
**Document Title: MATERIAL SUBMITTAL FOR EXTERNAL SIGNAGE**  
**Document No.: MMC-IRIE-IRIG-AR-MTS-0026-00**  
**Transmittal No.: 351-CSC-MMC-TRANS-**  
**Issued To : MENASCO MECHANICAL CONTRACTING LLC**

**Received Date: 14-June-2022**

Sn	Comments	Status	Issued Date	Signature
1	All material must comply with Authorities regulations and requirements	B	14/06/2022	WE
2	Coordination and other necessary approval is the contractor responsibility	B	14/06/2022	WE
3	Final approval subject to client & physical sample approval	B	14/06/2022	WE
4				
5				

Status	A	-	Approved with No Comments.
Status	<b>B</b>	-	<b>Approved with Comments. Contractor may proceed ensuring comments are addressed and incorporated. No resubmission is required.</b>
Status	C	-	<b>Revise and resubmit. Contractor may not proceed. Contractor to resubmit incorporating comments.</b>
Status	D	-	Rejected. No further resubmission is required.

Reviewed by: Eng. Wagdi Mohamed El  
Hassan El Samani  
Sr. Architect

Signature:   
Date: 14-06-2022





Project : H258900- -Expo -Welcome Plaza Sustainability SHOP DRAWING TRANSMITTAL (Architectural)

Client : EXPO2020 Reference No : H258904-SD-TRN-00027

Consultant : Joanna Revision : 0

Contractor : ALEC/ Date: 16-09-21

Sr. No.	Document/Drawing Ref:	Description	Rev.	Copies		Remarks
				Hard	Soft	
1	OV065-SPD-H25904-FO-6GF005	GROUND FLOOR PARTITION PLAN LOCAL GEM 09 AL FARWANIA LIGHT BOX PLAN,ELEVATION & SECTION	2	0	1	

Discipline  
 Architectural    Structural    Electrical    Mechanical    Others

Relevant Specification Section:

THIS SUBMITTAL INTENDED FOR  Approval    Information    Records

Name: \_\_\_\_\_ Sign & Stamp: \_\_\_\_\_

**For Consultant Use**

Comments:

1- Contractor to coordinate shop drawings and works with all other approved design drawings.  
2- Contractor to submit relevant inspection requests for approvals.  
3- Contractor to coordinate shop drawings and works with all other interface As-built drawings.  
4- Contractor to coordinate shop drawings and works with all Authority permits/Approved Drawings and subject to final authorities approval.  
5- Drawings to be stamped by AOR.  
6- All Material incorporated for the work shall be submitted for DAO/EXPO for review and Approval.

Approval Status    (A) Approved    (B) Approved with Comments    (C) Revise & Resubmit    (D) Rejected

Name: \_\_\_\_\_ Signature: \_\_\_\_\_ Date: \_\_\_\_\_

**For Client / Comments**

Comments:

Approval Status    (A) Approved    (B) Approved with Comments    (C) Revise & Resubmit    (D) Rejected

Name: \_\_\_\_\_ Signature: \_\_\_\_\_ Date: \_\_\_\_\_

Received Submittal: Consultant/Client

Khalid Khan  
20/09/2021



Received Commented Copy: Contractor

## SHOP DRAWING SUBMITTAL

Project :	Buti Al Mulla Residential Building G+P2+7 Floors on Plot No. 334-7223) Al Satwa, Dubai, UAE	Ref. No.:	2722/BAM/SD/203-CIVIL	Rev. 02
Project No. :	2722	Date:	20/04/2022	
Contractor:	TAK Construction LLC			
From:	Techcraft LLC	To:	ARCHCORP	

DESCRIPTION : Internal Signages (Direction Sign, Apartment Sign, Sign Placement &amp; Service Sign)

Sr. #	Drawing No.	Rev.	Drawing Title
1	2722- TAK - 109	2	Direction Sign Details
2	2722- TAK - 107 & 108	2	Apartment Sign Placement
3	2722- TAK - 101 to 106	2	Sign Placement Plan-Ground floor,Podium1, 1st floor,2nd floor, Roof Floor
4	2722- TAK - 109 ,110,111, 103, 112, 113	2	Service Sign Details
No. of Sets 01			Attachments

## DISCIPLINE:

- Civil     
  Structural     
  Architectural     
  Electrical     
  Mechanical  
 Other (Specify) \_\_\_\_\_

## SUBMITTED FOR

- Approval     
  Information / Records     
  Others

## CONTRACTOR CERTIFICATION / COMPLIANCE

- We certify that the Submitted Documents  
 Complies with Specifications     
  Is an alternative to the specified Documents, but  
 complies / supersedes with the intent of the  
 specified specifications at no additional cost to the client.

## FOR CONTRACTOR

Name: ANISH KV

Designation: PROJECT MANAGER

Signature:

Date:



Stamp:

Signature:

Date:

**RECEIVED BY CONSULTANT**ENGINEER COMMENTS:

ARCH'L NOTE:

- SEE COMMENTS ON DRAWINGS & UPDATE & SUBMIT FOR REFERENCE.
- CONTRACTOR TO PROVIDE SAMPLE FOR ARCHITECT & CLIENT REVIEW & APPROVAL.
- CONTRACTOR IS RESPONSIBLE FOR THE COMPLETENESS AND CORRECT MATCHING ROOM NAMES & LOCATIONS AS PER DRAWINGS
- CONTRACTOR TO COMPLY ALL RELATED AUTHORITY REQUIREMENTS INCLUDING MOUNTING HEIGHTS & LOCATIONS.

20220523\_JOPELLIWANAG\_ARCH

 Approved Approved with Comments Revise & Resubmit Rejected For InformationCONSULTANT

Resident Engineer

Date:

Arif Hasan

24.05.2022

CONTRACTOR

Received by:

Date:

# LIST OF PROJECTS

# PROJECTS

## List of On Going Jobs

	Client	Order date	Job
1	Jotun MEIA FZ LLC	08.06.2021	Signage
2	Jotun MEIA FZ LLC (façade sign)	18.08.2021	Signage
3	Jotun MEIA FZ LLC - Variation Order 1		Signage
4	East coast - Al Barsha	27.06.2021	Signage
5	Azizi Developments, Al Shamandi	28.07.2021	Signage
6	Farnek Mashreq Maintenance work	15.08.2021	Signage
7	Amana Schlumberger AJ-420, Signs	20.08.2021	Signage
8	Amana EKFC Signs	30.08.2021	Signage
9	Amana EKFC, Bustanica	10.09.2021	Signage
10	Amana Jotun Stainless Steel Works	20.09.2021	metal work
11	AZIZI Progress	23.09.2021	Internal Signs
12	Amana Steel Building	29.09.2021	Refurbishment of signs
13	Amana Jotun Metal Works	12.09.2021	Metal works
14	Jotun R & D Variation 1	31.10.2021	GRC Bracket
15	Jotun R & D Variation 2	19.01.2022	Site Welding work
16	Jotun R & D Variation 3	19.01.2022	Bike Rack
17	Amana Jotun R&D Laboratory & Regional Office, Floor & Wall Mounted Handrail for Staircase No. 1, 3, 4, 5 & 6	26.01.2022	Metal Works
18	Amana Schlumberger AJ-420	15.11.2021	Stainless Steel
19	Mithra Associates Trading	15.11.2021	Signage
20	Al Samadi Group	23.12.2021	Signage
21	UNEC Al Zahia	08.03.2022	Signage
22	Amana DJ 287 Logistics & Office Facility Extension DIP-2	13.04.2022	Signage
23	Tiger Contracting	26.04.2022	Signage
24	Khyber Tower Metal, Signage and Joinery works		Signage, Metal & Joinery
25	TAK Buti Al Mulla Project		Metal
26	TAK Buti Al Mulla Project- Aluminium scope / Signage work		Aluminium / Signage
27	TAK Safa School Metal Work		Metal
28	TAK Safa School Aluminium Scope / Signage work		Aluminium / Signage
29	TAK G+5 Project / Signage work		Aluminium / Signage
30	TAK Satguru Al Furjan / Signage work		Metal / Signage
31	Private villa for Mr. Praveen		Metal, Aluminium
32	Private villa for Mr. Teyab		Metal, Aluminium
33	G+19 IGO Tower / Signage work		Signage, Metal / Signage

# PROJECTS

	Completed jobs		
	Client	Order date	Job
1	G & B Construction	03.02.2020	Internal Signs
2	General Construction	08.08.2020	Inernal Signs
3	Bloom Heights	16.09.2020	Int. & Ext. Signage
4	East coast Al Raha	12.11.2020	Signage
5	RNT General Trading	11.01.2021	Stand
6	Dream Outdoor	12.01.2021	
7	Spectrami DMCC	20.01.2021	Stickers
8	Al Jazeera International Bld. Cont.LLC	25.01.2021	Sigange
9	Dream Outdoor	28.01.2021	
10	Triangez	18.02.2021	Stickers
11	Nray Marketing	23.02.2021	Signage
12	RNT General Trading	27.02.2021	Furniture
13	DBB Contracting	28.02.2021	Acrylic Light Box
14	Leaf Connect	06.03.2021	Display box
15	Green Source	07.03.2021	Grill to kitchen
16	Simpara Restaurant	31.04.2021	Stickers
17	Leaf Connect	09.05.2021	Display box
18	M/S PRE -STRESSING EXPANDED METAL COMPONENTS MANUFACTURING (L.L.C)	06.06.2021	Stickers
19	Wade Adams	21.06.2021	Fence Branding
20	Hemlock	04.07.2021	Stickers
21	M/S Biryaniwalla and Co Express Restaurant (Al Barsha)	24.07.2021	Signage
22	East coast - Al Barsha	23.08.2021	Signage
23	Farnek Mashreq Maintenance work	15.08.2021	Signage
24	Amana Fish Market	19.05.2021	Signage
25	Amana Fish Market Banner	12.10.2021	Banner
26	Amana Contracting, Al Dharfa	19.05.2021	Signage

## PROJECTS

	Completed jobs		
27	Amana Schlumberger AJ-420, Signs	20.08.2021	Signage
28	Amana Schlumberger AJ-420, Metal	15.11.2021	Metal
29	Leaf Connect	25.08.2021	Display box
30	Amana Jotun Stainless Steel Works	20.09.2021	metal work
31	Amana Steel Building Refurbishment of signs	29.09.2021	Refurbishment of signs
32	Hantco International General Trading L.L.C	20.09.2021	Signage
33	M/S COVENANT	20.09.2021	Signage
34	AZIZI Sandwich Panel	20.09.2021	Signage
35	Amana <b>EKFC Signs, Bustanica</b>	30.08.2021	Signage
36	Amana Contracting, AJ-450 <b>Aeroforms</b>	07.01.2022	Signage
37	Biryaniwalla - 5 locations	08.08.2021	Metal work
38	Alec <b>Expo Live Pavilion</b>	11.08.2021	Signage
39	Alec Expo- <b>Welcome Pavilion</b>	30.08.2021	Signage
40	Alec Engineering Expo, <b>Country Pavilion</b>	12.09.2021	Signage
41	<b>Jotun MEIA FZ LLC</b>	08.06.2021	Signage
42	<b>Jotun MEIA FZ LLC (façade sign)</b>	18.08.2021	Signage
43	AZIZI Sandwich Panel	20.09.2021	Signage
44	<b>DUPOD Fish Market Banner</b>	26.09.2021	Banner
45	Tropicool Food & Beverages Trading L.L.C	09.10.2021	Signage
46	<b>UNEC Club House</b>	17.10.2021	Signage
47	General Construction	13.12.2021	Signage
48	Mithra Associates Trading	15.11.2021	Signage
49	Green Source	14.12.2021	Signage
50	Al Samadi Group	23.12.2021	Signage
51	Al Mehbash Roastery	07.01.2022	Signage
52	Amana Aeroforms	07.01.2022	Signage
53	Leaf Connect	12.01.2022	Display box
54	Khyber Investmetns Limited	17.01.2022	Signage
55	East Coast Contracting, <b>Iris Site</b>	21.01.2022	Signage



# PROJECTS

56	Shelving Trading LLC	05.02.2022	Stencil Painting
57	Fashion Forward LLC, Sharaf Retail Circle Mall	07.02.2022	Signage
58	Fashion Forward LLC, Sharaf Retail Circle Mall	14.02.2022	Signage
59	Shelving Trading LLC	25.02.2022	Acrylic cut out
60	Afarirs Exhibition	26.02.2022	Back drop, Roll ups
61	Leaf Connect	01.03.2022	Speaker Display Stand
62	360 Advertising LLC	06.03.2022	Signage
63	Dubai Police	07.03.2022	Signage
64	Union Plastics	18.03.2022	Exhibition Stand
65	Fashion Forward	18.03.2022	Signage
66	Avenue Mall	25.03.2022	Signage
67	Air Arabia		
68	Saadiyat	06.04.2022	Signage
69	Fashion Forward	18.04.2022	Signage
70	M/S Anwar Al Raqia Technical Works L.L.C	15.04.2022	Aluminium Door
71	M/S Fount Pools & Landscaping LLC	22.04.2022	Signage
72	Union Plastics	07.05.2022	Exhibition Stand - Beyond Connect
73	EKFC CENTRAL KITCHEN FACILITY AT DUBAI SOUTH		SUPPLY AND EXTERNAL & INTERNAL SIGNS
73	104+B+G+R COMMERCIAL BUILDING, AL BARSHA		SUPPLY OF INTERNAL SIGNS
74	WENDY'S AL SAQR BUSINESS TOWER, SHEIKH ZYED ROAD		SIGNAGE MAINTENANCE WORKS- EXTERNAL SIGNS
75	NAD AL SHIBA AVENUE, NAD AL SHIBA		INTERNAL SIGNS
76	BLOOM TOWERS, JVC		PARKING SIGNS
77	LOST & FOUND, DUBAI POLICE.AL KHAWANEEJ		EXTERNAL & INTERNAL SIGNS
78	AL HAMARIYA RESIDENCE, BURDUBAI		EXTERNAL & INTERNAL SIGNS



# RECOMMENDATION LETTERS

FIRSTNAME .....

LAST NAME .....

COUNTRY YOU ARE REPRESENTING .....

Enclose to this form:

1. Artist biography approx. 150 words

Attention! The biography must be written by the artist. Biographies written by others will not be accepted.

2. One slide or photograph of the artist's work.

the right of non publishing

publish on the

TITLE .....

TECH .....

- Indic (base, i

of the l

- The pho

Signature \_\_\_\_\_

To:

**Tech Craft Advertising & Signs L.L.C****Dubai Investment Park - 2****P.O. Box: 487131****Dubai - U.A.E****Tel: +971 4 288 0945****To Whom It May Concern**

We would like to express our sincere appreciation to **M/s Tech Craft Advertising & Signs L.L.C** for completing the signage works for projects **Bloom Towers** (3 Towers -Tower A-G+4P+39 Floors, Tower B&C-G+4P+29Floors) & **Bloom Heights** (G+4P+29&24 Floors-2 Towers) Residential Building & Retail) on time, within the budget and consistently following HSE rules and regulations. In recognition of outstanding performance and conscientious efforts, we appreciate **M/s Tech Craft Advertising & Signs L.L.C** team for their professionalism and interest in the projects. Deliveries were often received earlier than expected and you were quick to resolve any issues that arise during the execution of the Project.

We congratulate every team fellow on the project, it was a prodigious time to work with your team and we affirm that **M/s Tech Craft Advertising & Signs L.L.C** shall be on our top preference list for such kinds of projects. We look forward to a much more fruitful business Association in future.

For **Al Oroba Contracting Co. LLC****Eng. Ahmed Abdul Baqy**

General Manager



شركة العروبة للمقاولات (ذ.م.م.)  
**Al Oroba Contracting Co. (L.L.C)**  
P.O. Box: 60197  
ص.ب: ٦٠١٩٧  
دبي - ا.ع.م.  
Dubai - U.A.E.

**Abu Dhabi (Branch):**

Tel.: 02-6503931

Fax: 02-6503919

P.O. Box: 108500, Abu Dhabi

**أبو ظبي (فرع):**

هاتف: ٠٢-٦٥٠٣٩٣١

فاكس: ٠٢-٦٥٠٣٩١٩

ص.ب: ١٠٨٥٠٠، أبو ظبي

ALEC Engineering and Contracting L.L.C  
أليك للهندسة والمقاولات ذ.م.م

أبوظبي  
مبنى علي خليفة راشد المطوع الظاهري  
وحدة رقم ٢٠٥  
ص.ب. ٤٥٣٣٦  
أبوظبي، الإمارات العربية المتحدة  
هاتف: +٩٧١ ٢ ٥٥٦ ٧٥٤٠  
فاكس: +٩٧١ ٢ ٥٥٦ ٣٤٤٦

دبي  
٣٦٠١ مارينا بلازا  
دبي مارينا  
ص.ب. ٢٧٦٣٩  
دبي، الإمارات العربية المتحدة  
هاتف: +٩٧١ ٤ ٤٢٩ ٠٥٩٩  
فاكس: +٩٧١ ٤ ٤٢٩ ٠٢١٦

Our Reference: ALEC-CBC352-LO-AN-0012

18 July 2022

**Tech Craft Advertising & Signs L.L.C**  
**Dubai Investment Park - 2**  
**P.O. Box: 487131**  
**Dubai, U.A.E**  
**Tel: +971 4 288 0945**

Subject: Appreciation Letter  
Project: EXPO 2020 Projects

Dear Sir/Madam,

We hereby express our gratitude and appreciation for the huge effort, support and cooperation provided by Tech Craft Advertising & Signs L.L.C to ALEC Engineering and Contracting LLC in accomplishing and completing the below listed projects for Expo 2020 in an honorable and prestigious manner, with great professionalism and in compliance with the project programme.

- Expo Live Pavilion (Metalwork)
- Welcome Plaza (Expo Overlay -Metalwork)
- Al Farwania (Signage)
- Al Reef Bakery (Signage)
- Country Pavilion (Signage) for Argentina, Uruguay, Panama, and Iraq Pavilions

We applaud the high standards upheld during the engineering, fabrication and installation of works on these Pavilions whilst under immense pressure with the short project durations to meet the opening of the Expo 2020 event. Credit must be given to the entire Tech Craft Advertising & Signs L.L.C team, with special mention to Ms Abeer for stepping in and providing unconditional support and solutions to the ALEC project team during execution of these complex projects for Expo 2020.

We would take this opportunity to thank Tech Craft Advertising & Signs L.L.C for all the support and cooperation provided and look forward to continued success and building on the good business relations established thus far.

Yours faithfully,  
**For and behalf of ALEC Engineering and Contracting L.L.C.**



**Abdul Qayum Nacerodien**  
**Commercial Manager**

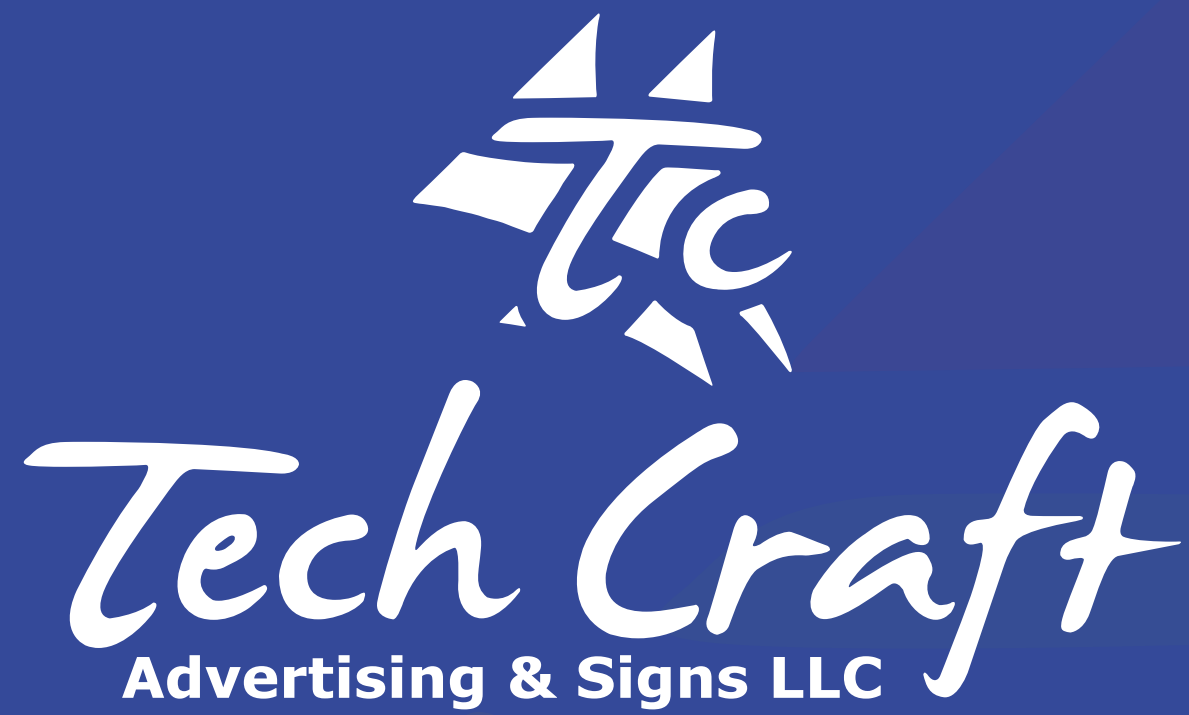

## CONTACT US

Tech Craft Advertising & Signs LLC

Plot No: 597-732, Dubai Investment Park – 2,  
Po Box – 487131, Dubai - United Arab Emirates.

Talal Humaid Abdulla Belhoul Warehouse

Email ID: [info@techcraft.tech](mailto:info@techcraft.tech)

Mob: +971 56 411 3796, Tel: +971 4 288 0945

Web: [www.techcraftdubai.com](http://www.techcraftdubai.com)

